

Table of Contents

Chapter 1: Getting Started	1
Examination before Installation	2
Environmental Precautions	2
SG2 Model Identification	3
Quick Start Setup	4
Chapter 2: Installation	10
General Specifications	10
Product Specifications	12
Mounting	13
Wiring	15
Chapter 3: Program Tools	18
PC Programming Software “SG2 Client”	18
Memory Cartridge	26
LCD Display and Keypad	27
Chapter 4: Relay Ladder Logic Programming	44
Common Memory Types	44
Specialty Memory Types	46
Output Instructions	47
Counter Instructions	49
High Speed Counters (DC Version Only)	55
Timer Instructions	57
Real Time Clock (RTC) Instructions	65
Comparator Instructions	70
HMI Display Instructions	72
PWM Output Instruction (DC Transistor Output Models Only)	74
Data Link/Remote I/O Instruction (SG2-20Vxx Models Only)	75
Chapter 5: Function Block Diagram Programming	77
Coil Block Instruction	77
PWM Function Block	78
SHIFT Function Block	79
Logic Block Instructions	80
AND Logic Block	80
AND (Edge) Logic Block	80
NAND Logic Block	81
NAND (Edge) Logic Block	81
OR Logic	81

NOR Logic	81
XOR Logic	82
SR Logic Block	82
NOT Logic Block	82
Pulse Logic Block	82
Function Block	83
Common Counter Function Block	83
High Speed Counter Function Block	84
Timer Function Block	85
RTC Function Block	86
Analog comparator Function Block	87
Appendix: Application Illustration	89

Chapter 1: Getting Started

The SG2 tiny smart Relay is an electronic device. For safety reasons, please carefully read and follow the paragraphs with "WARNING" or "CAUTION" symbols. They are important safety precautions to be aware of while transporting, installing, operating, or examining the SG2 Controller.



WARNING: Personal injury may result from improper operation.



CAUTION: The SG2 smart relay may be damaged by improper operation.

Precaution for Installation



Compliance with the installation instructions and the user manual is absolutely necessary. Failure to comply could lead to improper operation, equipment damage or in extreme cases even death, serious bodily injury or considerable damage to property.



When installing the open-board models, insure that no wiring or foreign materials can fall into the exposed circuits and components. Damage to equipment, fire, or considerable damage to property could result.



Always switch off power before you wire, connect, install, or remove any module.



The wiring for the SG2 smart relay is open and exposed. For the open-board models, all electrical components are exposed. For this reason, it is recommended the SG2 smart relay be installed in an enclosure or cabinet to prevent accidental contact or exposure to the electrical circuits and components.



Never install the product in an environment beyond the limits specified in this user manual such as high temperature, humidity, dust, corrosive gas, vibration, etc.

Precaution for Wiring



Improper wiring and installation could lead to death, serious bodily injury or considerable damage to property.



The SG2 smart relay should only be installed and wired by properly experienced and certified personnel.



Make sure the wiring of the SG2 smart relay meets all applicable regulations and codes including local and national standards and codes.



Be sure to properly size cables for the required current rating.



Always separate AC wiring, DC wiring with high-frequency switching cycles, and low-voltage signal wiring.

Precaution for Operation



To insure safety with the application of the SG2 smart relay, complete functional and safety testing must be conducted. Only run the SG2 after all testing and confirming safe and proper operation is complete. Any potential faults in the application should be included in the testing. Failure to do so could lead to improper operation, equipment damage or in extreme cases even Death, serious bodily injury or considerable damage to property.



When the power is on, never contact the terminals, exposed conductors or electrical components. Failure to comply could lead to improper operation, equipment damage or in extreme cases even death, serious bodily injury or considerable damage to property.



It is strongly recommended to add safety protection such as an emergency stop and external interlock circuit in case the SG2 smart relay operation must be shut down immediately.

Examination before Installation

Every SG2 smart relay has been fully tested and examined before shipment. Please carry out the following examination procedures after unpacking your SG2 smart relay.

- Check to see if the model number of the SG2 matches the model number that you ordered.
- Check to see whether any damage occurred to the SG2 during shipment. Do not connect the SG2 smart relay to the power supply if there is any sign of damage.

Contact  if you find any abnormal conditions as mentioned above.

Environmental Precautions

The installation site of the SG2 smart relay is very important. It relates directly to the functionality and the life span of your SG2. Please carefully choose an installation site that meets the following requirements:

- Mount the unit vertically
- Environment temperature: 32°F - 131°F (0°C - 55°C)
- Avoid placing SG2 close to any heating equipment
- Avoid dripping water, condensation, or humid environment
- Avoid direct sunlight
- Avoid oil, grease, and gas
- Avoid contact with corrosive gases and liquids
- Prevent foreign dust, flecks, or metal scraps from contacting the SG2 smart relay
- Avoid electric-magnetic interference (soldering or power machinery)
- Avoid excessive vibration; if vibration cannot be avoided, an anti-rattle mounting device should be installed to reduce vibration.

SG2 Model Identification

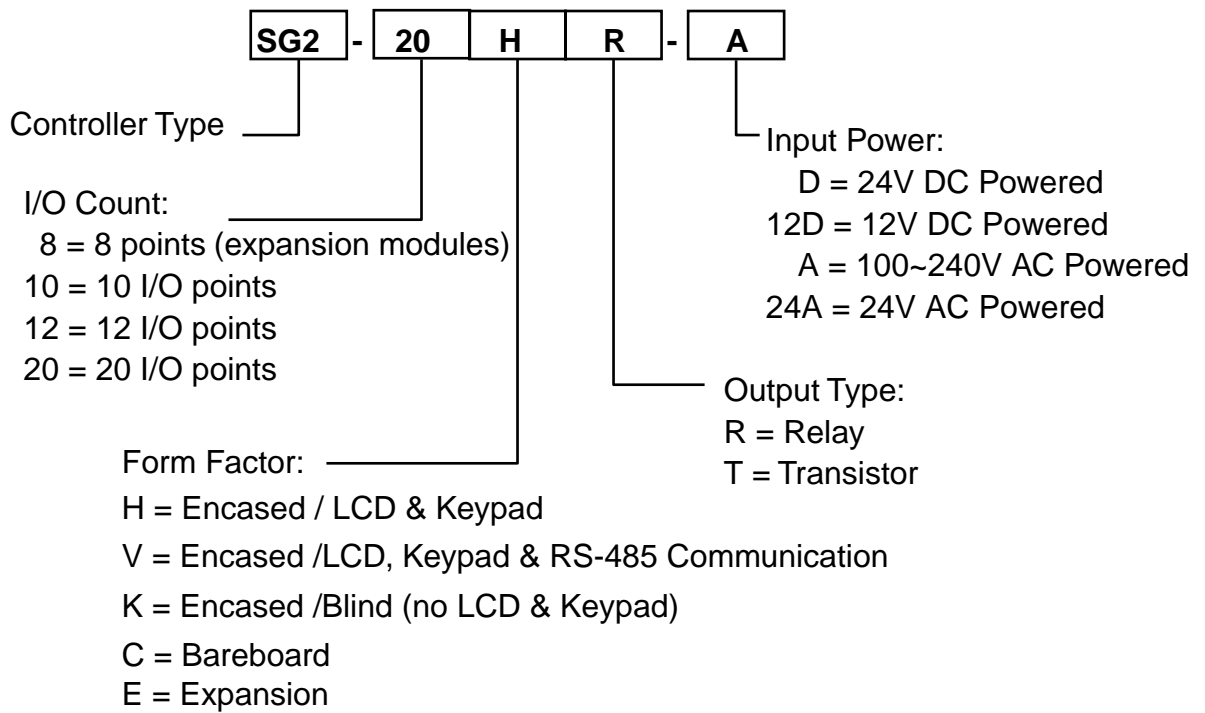

Quick Start Setup

This section is a simple 5-steps guide to connecting, programming and operating your new SG2 smart relay. This is not intended to be the complete instructions for programming and installation of your system. Many steps refer to other sections in the manual for more detailed information.

1. Install SG2 Client Software

Install the SG2 Client Software from CD or from the free internet download at www.taian-technology.com



2. Connect Power to SG2 smart relay

Connect power to the Smart Relay using the below wiring diagrams for AC or DC supply for the applicable models. See "Chapter 2: Installation" for complete wiring and installation instructions

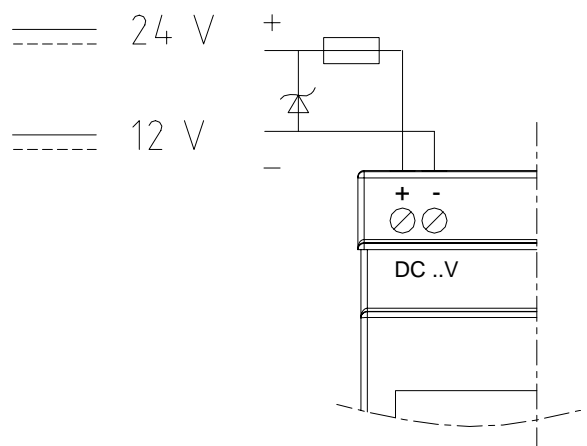
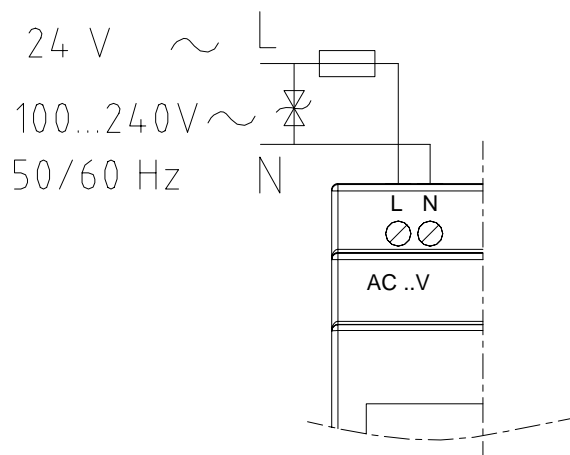

3. Connect Programming Cable

Remove the plastic connector cover from the SG2 using a flathead screwdriver as shown in the figure below. Insert the plastic connector end of the programming cable into the SG2 smart relay as shown in the figure below. Connect the opposite end of the cable to an RS232C serial port on the computer.

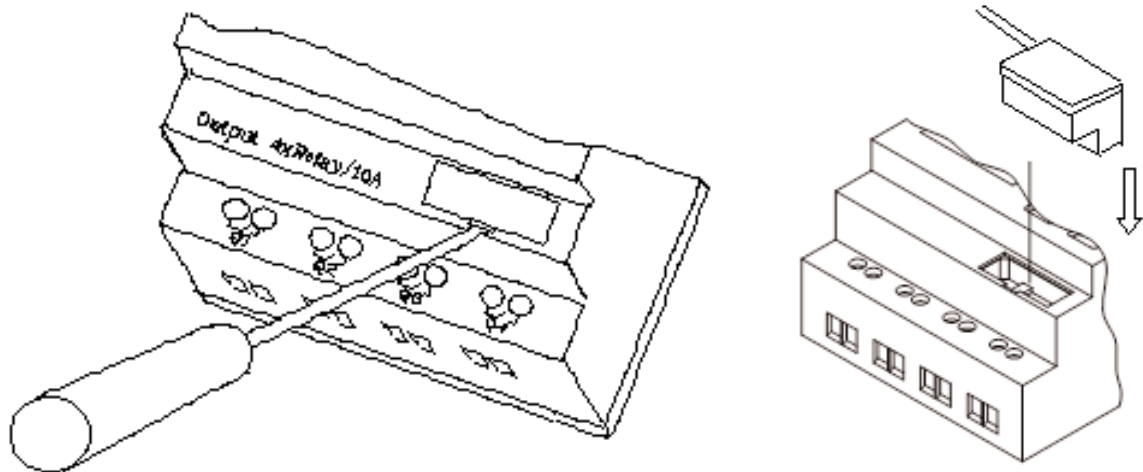

4. Establish Communication

- a. Open the SG2 Client software and select “New Ladder Document” as shown below.

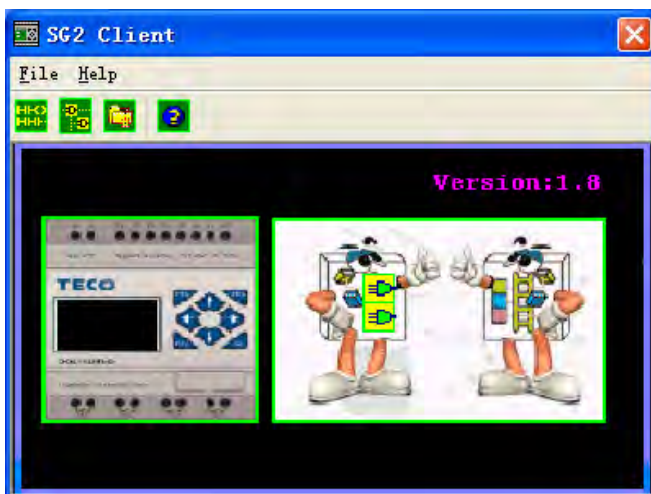

- b. Select “Operation/Link Com Port...” as shown

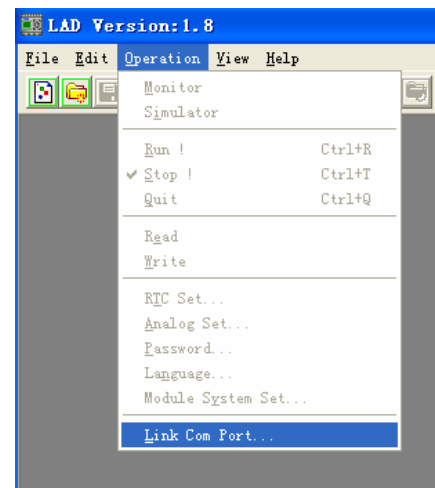

- c. Select the correct Com Port number where the programming cable is connected to the computer then press the “Link” button.

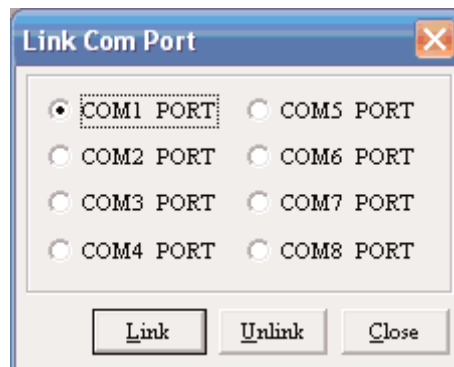

- d. The SG2 Client will then begin to detect the connected smart relay to complete its connection as shown below.

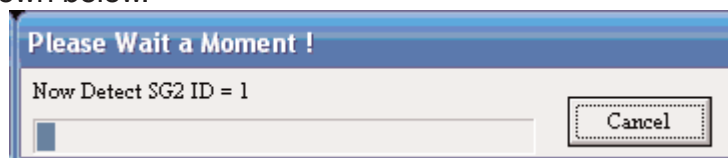

5. Write simple program

- a. Write a simple one rung program by clicking on the leftmost cell at line 001 of the programming grid, then click on the “M” contact icon on the ladder toolbar, as shown below. Select M1 and press the OK button. See Chapter 4: Ladder Programming instructions for complete instruction set definitions.

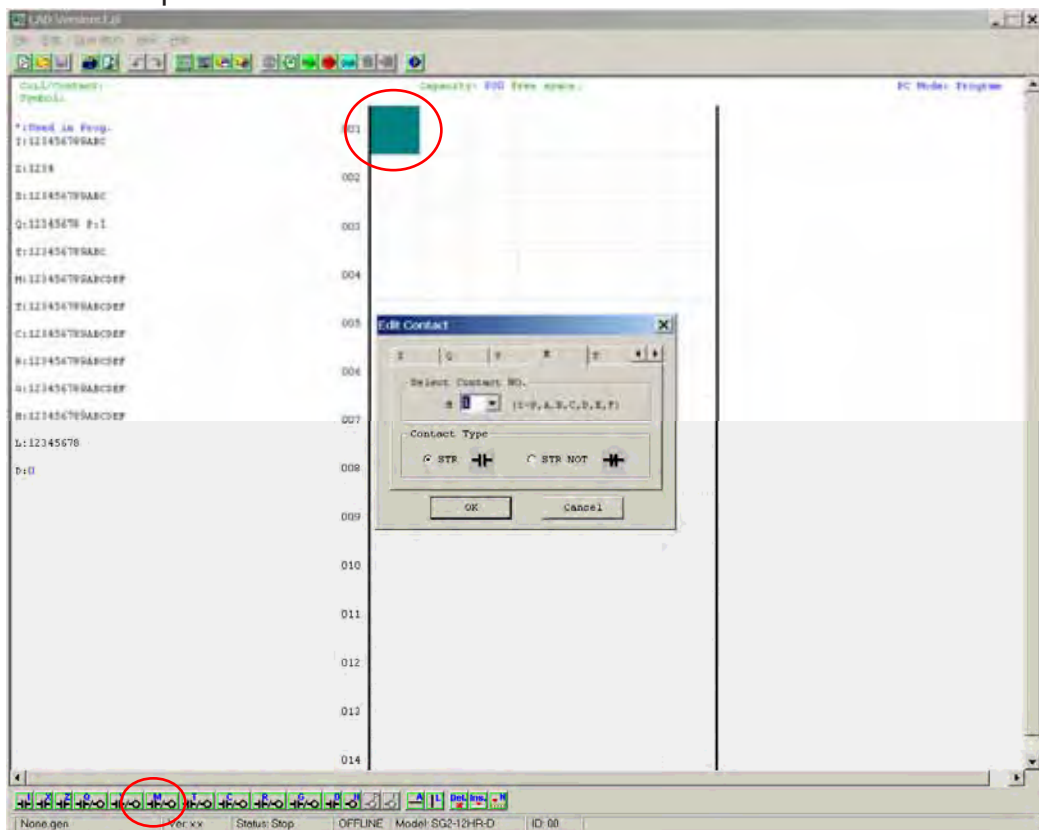

Note: If the ladder toolbar is not visible at the bottom of the screen, select View>Ladder Toolbar from the menu to enable.

- b. Use the “A” key on your keyboard (or the “A” icon from the ladder toolbar) to draw the horizontal circuit line from the M contact to the right most cell, as shown below.

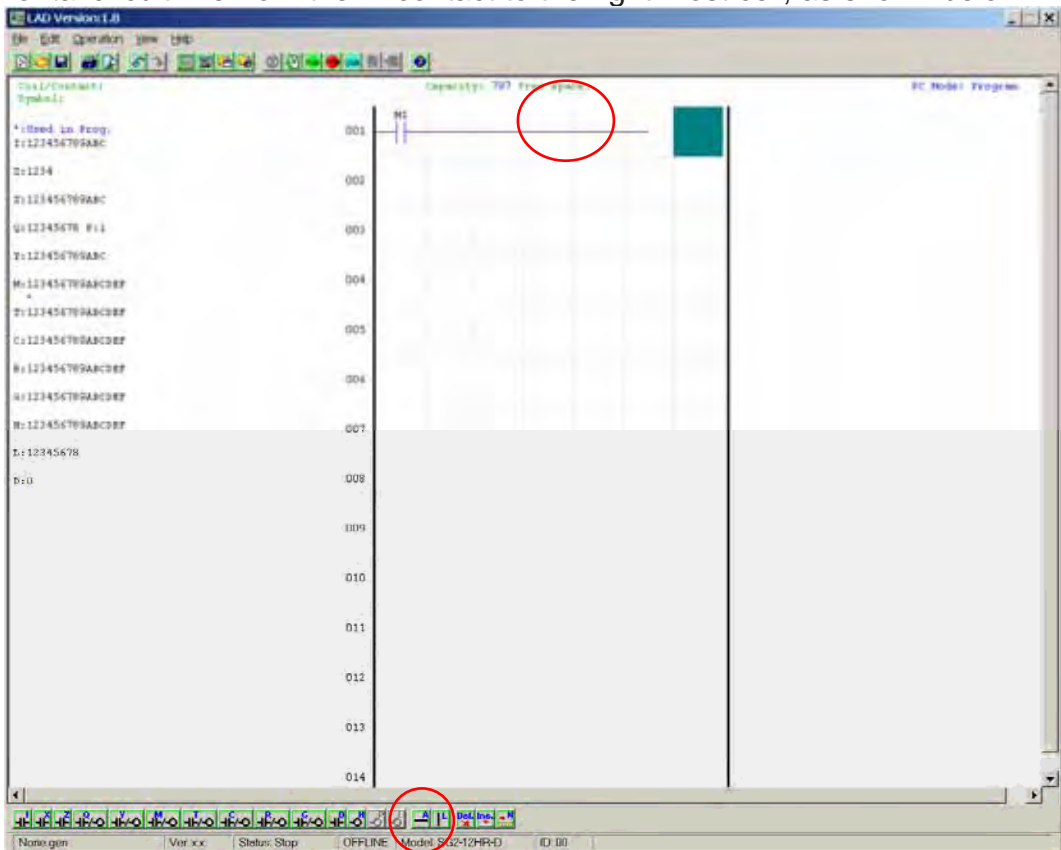

- c. Select the “Q” coil icon from the ladder toolbar and drop it on the right most cells. Select Q1 from the dialog and press OK as shown below. See Chapter 4: Ladder Programming instructions for complete instruction set definitions.

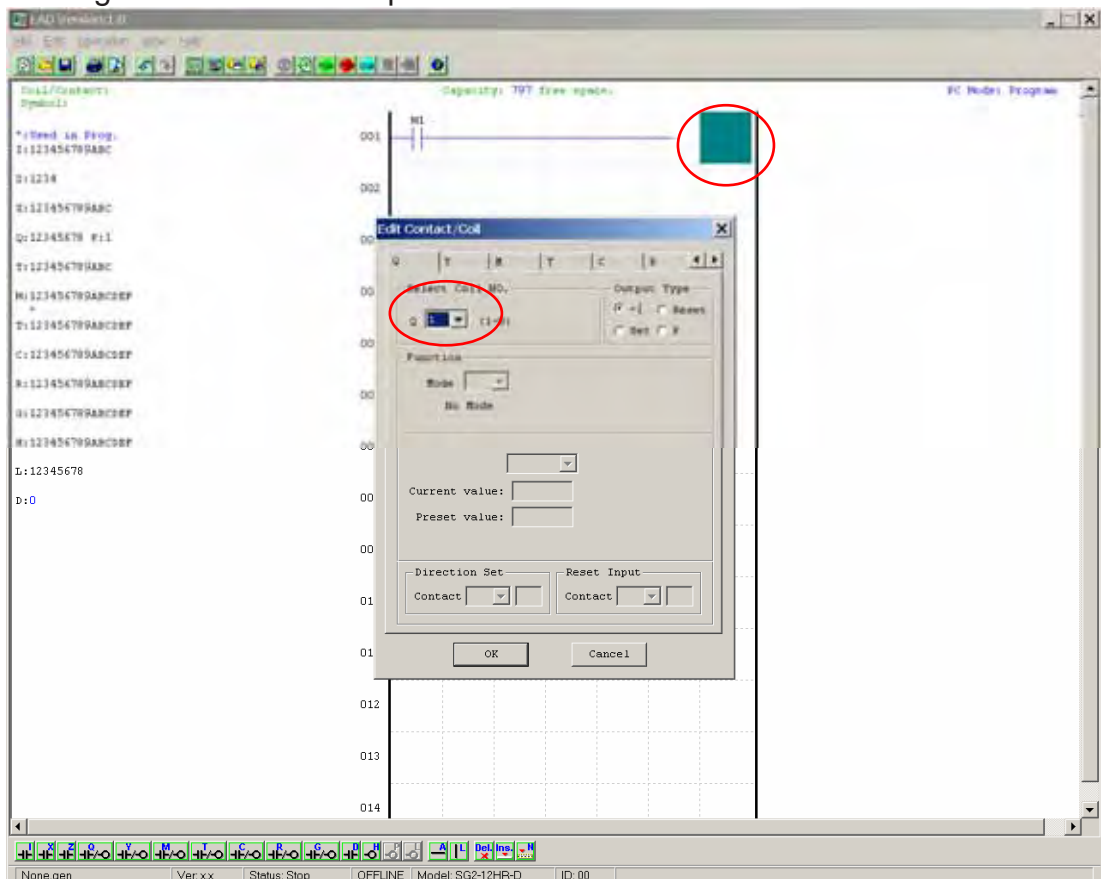

- d. Test the simple program. From the Operation menu, select the Write function and write the program to the connected smart relay as shown below.

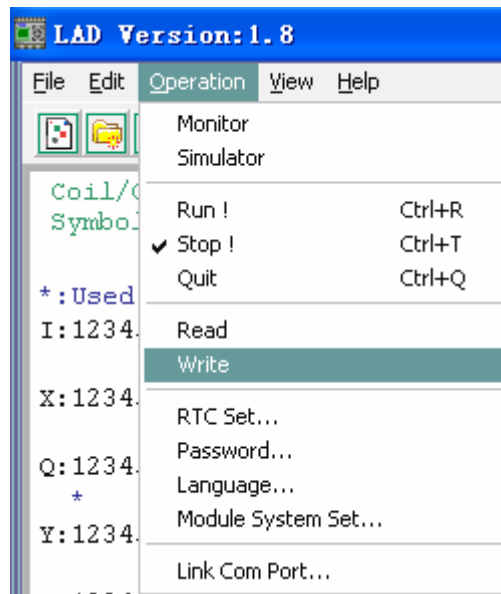

- e. Select the RUN icon from the toolbar, and select "No" when the pop-up message asks "Do you want to read program from module?", as shown below.

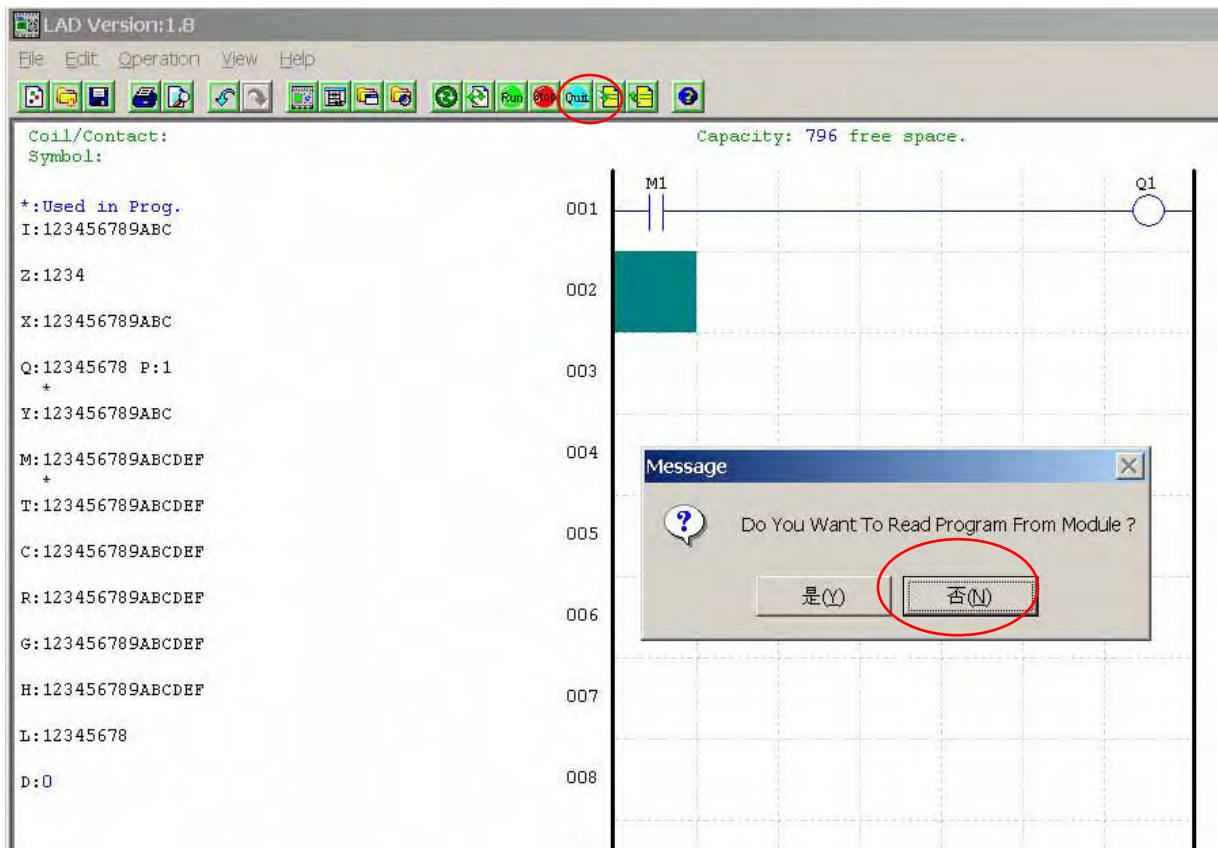

- f. From the Input Status dialog, click on M1 to activate the contact M1 which will turn ON the Output Q1, as shown below. The highlighted circuit will show active and the first Output (Q1) on the connected smart relay will be ON. See Chapter 3: Programming Tools for more detailed software information.

The screenshot displays the LAD software interface. On the left, a list of coils and contacts is shown, including I, X, Q, Y, M, T, C, R, G, H, and L. The 'Input Status Tool' dialog is open, showing a grid of status indicators for various inputs. The 'M1' section is circled in red, and the 'On' button is highlighted. The ladder logic diagram on the right shows a contact labeled 'M1' connected to an output coil labeled 'Q1'.

Capacity: 796 free space.

Cell/Contact:
Symbol:

+: Status On
I: 123456789ABC
Z: 1234
X: 123456789ABC
Q: 12345678 P: 1
Y: 123456789ABC
M: 123456789ABCDEF
T: 123456789ABCDEF
C: 123456789ABCDEF
R: 123456789ABCDEF
G: 123456789ABCDEF
H: 123456789ABCDEF
L: 12345678

Input Status Tool

I: 1 2 3 4 5 6
 On
 Off

Z: 1 2 3 4
 On
 Off

M: 1 2 3 4 5 6
 On
 Off

7 8 9 A B C
 On
 Off

D E F
 On
 Off

X: 1 2 3 4 5 6
 On
 Off

7 8 9 A B C
 On
 Off

001 M1 Q1
002
003
004
005
006
007
008
009
010

Chapter 2: Installation

General Specifications

SG2 is a miniature smart Relay with a maximum of 44 I/O points and can be programmed in Relay Ladder Logic or FBD (Function Block Diagram) program. The SG2 can expand to its maximum I/O count by adding 3 groups of 4-input and 4-output modules.

Power Supply	
Input Power Voltage Range	24V DC Models: 20.4-28.8V; 12V DC Models: 10.4~14.4V AC Models: 85-265V; 24V AC Models: 20.4-28.8V
Power Consumption	24VDC: 12-point : 90mA ; 20-point: 150mA ; 12VDC: 12-point: 150mA ; 20-point: 240mA ; 100-240VAC: 90mA ; 24VAC: 290mA ;
Wire Size (all terminals)	26 to 14 AWG
Programming	
Programming languages	Ladder/Function Block Diagram
Program Memory	200 Lines or 99 Function Blocks
Programming storage media	Flash
Execution Speed	10ms/cycle
LCD Display	4 lines x 12 characters
Timers	
Maximum Number	15
Timing ranges	0.01s–9999min
Counters	
Maximum Number	15
Highest count	999999
Resolution	1
RTC (Real Time Clock)	
Maximum Number	15
Resolution	1min
Time span available	week, year, month, day, hour, min
Compare Instructions (Analog, Timer, or Counter Values)	
Maximum Number	15
Compare versus other inputs	Analog, Timer, Counter, or Numeric values
Environmental	
Enclosure Type	IP20
Maximum Vibration	1G according to IEC60068-2-6
Operating Temperature Range	32° to 131°F (0° to 55°C)
Storage Temperature Range	-40° to 158°F (-40° to 70°C)
Maximum Humidity	90% (Relative, non-condensing)
Vibration	0.075mm amplitude, 1.0g acceleration
Weight	8-point:190g 10,12-point: 230g (C type: 160g) 20-point: 345g (C type: 250g)
Agency Approvals	cUL , CE, UL

Discrete Inputs	
Current consumption	3.2mA @24VDC 4mA @12VDC 1.3mA @100-240VAC 3.3mA @24VAC
Input Signal "OFF" Threshold	24VDC: < 5VDC; 12VDC: < 2.5VDC 100-240VAC : < 40VAC 24VAC: <6VAC
Input Signal "ON" Threshold	24VDC: > 15VDC; 12VDC: > 7.5VDC 100-240VAC : > 79VAC 24VAC: >14VAC
Input On delay	24, 12VDC: 5ms 240VAC: 25ms; 120VAC: 50ms 24VAC: 5ms
Input Off Delay	24, 12VDC: 3ms 240VAC: 90ms; 120VAC: 50ms 24VAC: 3ms
Transistor device compatibility	PNP, 3-wire device only
High Speed Input frequency	1kHz
Standard Input frequency	< 40 Hz
Required protection	Inverse voltage protection required
Analog Inputs	
Resolution	Basic unit: 10 bit Expansion unit: 12bit
Voltage Range acceptable	Basic unit: Analog input: 0-10VDC voltage, 24VDC when used as discrete input; Expansion unit: Analog input: 0-10VDC voltage or 0-20mA current
Input Signal "OFF" Threshold	< 5VDC (as 24VDC discreet input)
Input Signal "ON" Threshold	> 9.8VDC (as 24VDC discreet input)
Isolation	None
Short circuit protection	Yes
Total number available	Basic unit: A1-A4 Expansion unit: A5-A8
Relay Outputs	
Contact material	Ag Alloy
Current rating	8A
HP rating	1/3HP@120V 1/2HP@250V
Maximum Load	Resistive: 8A /point Inductive: 4A /point
Maximum operating time	10ms (normal condition)
Life expectancy (rated load)	100k operations
Minimum load	16.7mA
Transistor Outputs	
PWM max. output frequency	0.5kHz (1ms on,1ms off)
Standard max. output frequency	100Hz
Voltage specification	10-28.8VDC
Current capacity	1A
Maximum Load	Resistive: 0.5A/point Inductive: 0.3A/point
Minimum Load	0.2mA

Product Specifications

Part #	Input Power	Inputs	Outputs	Display & Keypad	RS-485 Communications	Max I/O
SG2-12HR-D	24 VDC	6 DC, 2 Analog	4 Relay	, Z1-Z4	N/A	36 + 4 *1
SG2-12HT-D		6 DC, 2 Analog	4 Trans.	, Z1-Z4	N/A	36 + 4 *1
SG2-20HR-D		8 DC, 4 Analog	8 Relay	, Z1-Z4	N/A	44 + 4 *1
SG2-20HT-D		8 DC, 4 Analog	8 Trans.	, Z1-Z4	N/A	44 + 4 *1
SG2-20VR-D		8 DC, 4 Analog	8 Relay	, Z1-Z4	Built-in MODBUS	44 + 4 *1
SG2-20VT-D		8 DC, 4 Analog	8 Trans.	, Z1-Z4	Built-in MODBUS	44 + 4 *1
SG2-12HR-12D	12 VDC	6 DC, 2 Analog	4 Relay	, Z1-Z4	N/A	36 + 4 *1
SG2-20HR-12D		8 DC, 4 Analog	8 Relay	, Z1-Z4	N/A	44 + 4 *1
SG2-20VR-12D		8 DC, 4 Analog	8 Relay	, Z1-Z4	Built-in MODBUS	44 + 4 *1
SG2-10HR-A	100-240 VAC	6 AC	4 Relay	, Z1-Z4	N/A	34 + 4 *1
SG2-20HR-A		12 AC	8 Relay	, Z1-Z4	N/A	44 + 4 *1
SG2-12HR-24A	24VDC	8 AC	4 Relay	, Z1-Z4	N/A	36 + 4 *1
SG2-20HR-24A		12 AC	8 Relay	, Z1-Z4	N/A	44 + 4 *1
Expansion Modules						
SG2-8ER-D	24VDC	4 DC	4 Relay	N/A	N/A	N/A
SG2-8ET-D		4 DC	4 Trans.	N/A	N/A	N/A
SG2-8ER-A	100-240VAC	4 AC	4 Relay	N/A	N/A	N/A
SG2-8ER-24A	24VAC	4 AC	4 Relay	N/A	N/A	N/A
SG2-4AI	24 VDC	4 Analog	N/A	N/A	N/A	N/A
SG2-MBUS		Communications Module, RS-485 ModBus RTU slaver				
SG2-DNET		Communications Module, DeviceNet Group2 slaver				
SG2-PBUS		Communications Module, Profibus-DP slaver				
EN01		Communications Module, TCP/IP				
OEM "Blind" Models, No Keypad, No Display						
SG2-12KR-D	24VDC	6 DC, 2 Analog	4 Relay	X	N/A	36
SG2-12KT-D		6 DC, 2 Analog	4 Trans.	X	N/A	36
SG2-20KR-D		8 DC, 4 Analog	8 Relay	X	N/A	44
SG2-20KT-D		8 DC, 4 Analog	8 Trans.	X	N/A	44
SG2-12KR-12D	12VDC	6 DC, 2 Analog	4 Relay	X	N/A	36
SG2-10KR-A	100-240VAC	6 AC	4 Relay	X	N/A	34
SG2-20KR-A		12 AC	8 Relay	X	N/A	44
OEM "Bareboard" Models, No Keypad, No Display, No Expansion						
SG2-12CR-D	24VDC	6 DC, 2 Analog	4 Relay	X	N/A	12
SG2-12CT-D		6 DC, 2 Analog	4 Trans.	X	N/A	12
SG2-20CR-D		8 DC, 4 Analog	8 Relay	X	N/A	20
SG2-20CT-D		8 DC, 4 Analog	8 Trans.	X	N/A	20
SG2-10CR-A	100-240VAC	6 AC	4 Relay	X	N/A	10
SG2-20CR-A		12 AC	8 Relay	X	N/A	20
Accessories						
SG2-PL01	SG2 Programming Cable, SG2 Programming software					
SG2-PM05	SG2 Memory cartridge					

*1: If module with keypad and display, Max IO can be added keypad input Z1-Z4.

Mounting

DIN-rail Mounting

The SG2 smart relay should always be mounted vertically. Press the slots on the back of the SG2 and expansion module plug CONNECTOR onto the rail until the plastic clamps hold the rails in place. Then connect the expansion module and CONNECTOR with the Master (press the PRESS-BUTTON simultaneously)

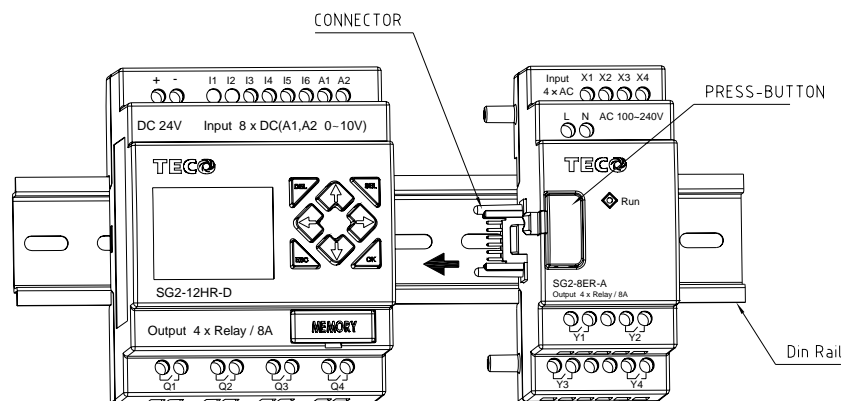
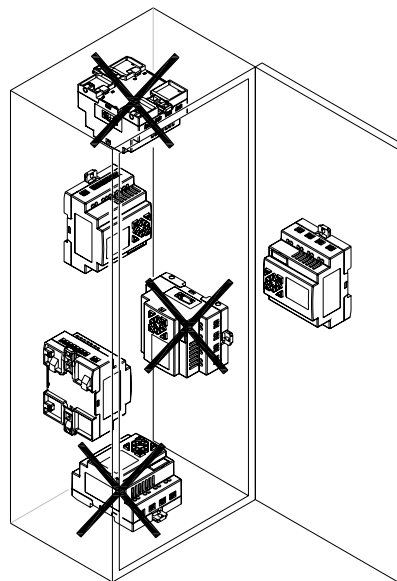
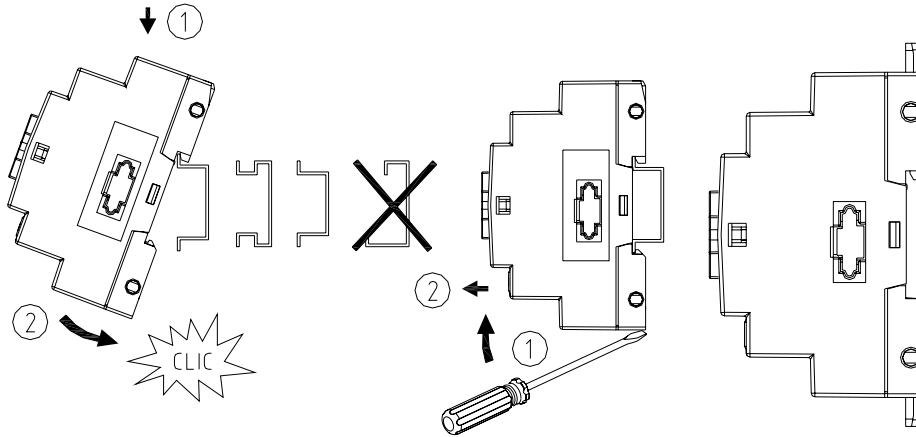

It is recommended to apply a DIN-rail end clamp to hold the SG2 in place.

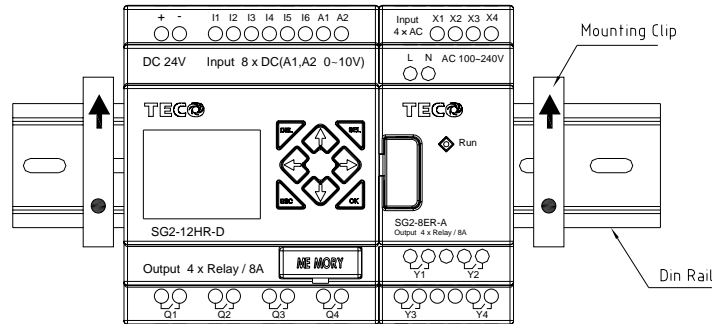

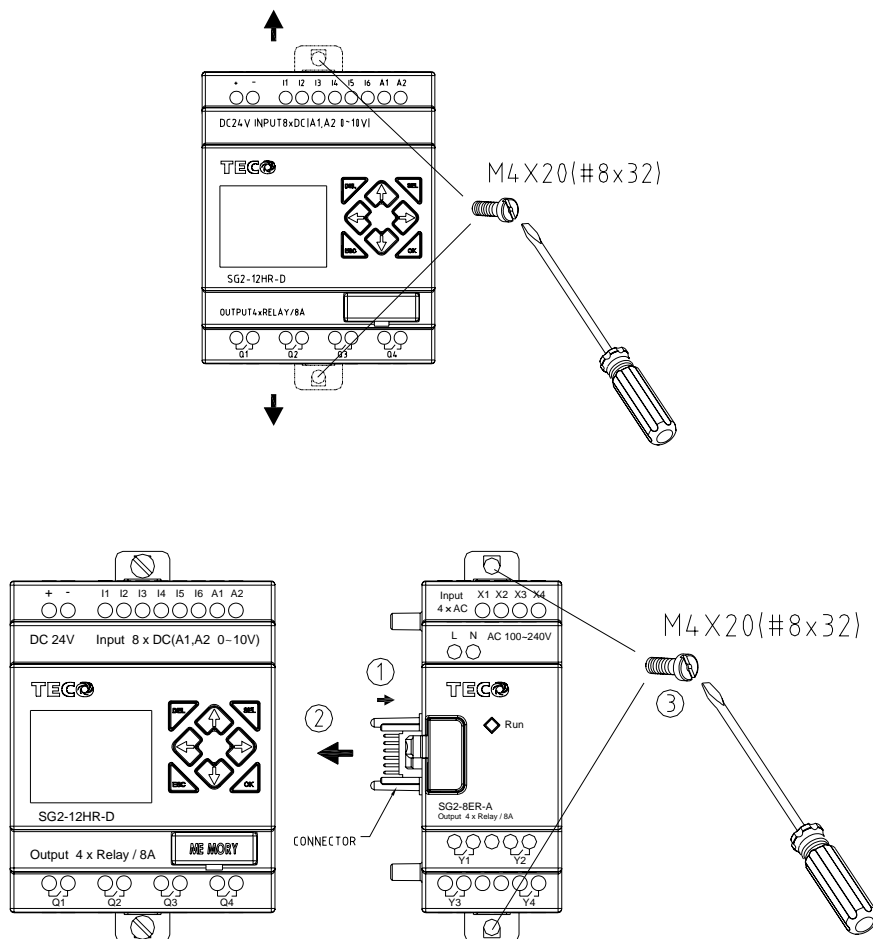

Direct Mounting

Use M4 screws to direct mount the SG2 as shown. For direct installation of the expansion module, slide the expansion module and connect with the Master after the Master is fixed.









Wiring

 **WARNING:** The I/O signal cables should not be routed parallel to the power cable, or in the same cable trays to avoid the signal interference.

 To avoid a short circuit on the load side, it is recommended to connect a fuse between each output terminals and loads.

Wire size and Terminal Torque

					
mm ²	0.14...1.5	0.14...0.75	0.14...2.5	0.14...2.5	0.14...1.5
AWG	26...16	26...18	26...14	26...14	26...16
					
Ø 3.5 (0.14in)	C	Nm	0.6		
		lb-in	5.4		

Input 12/24V DC

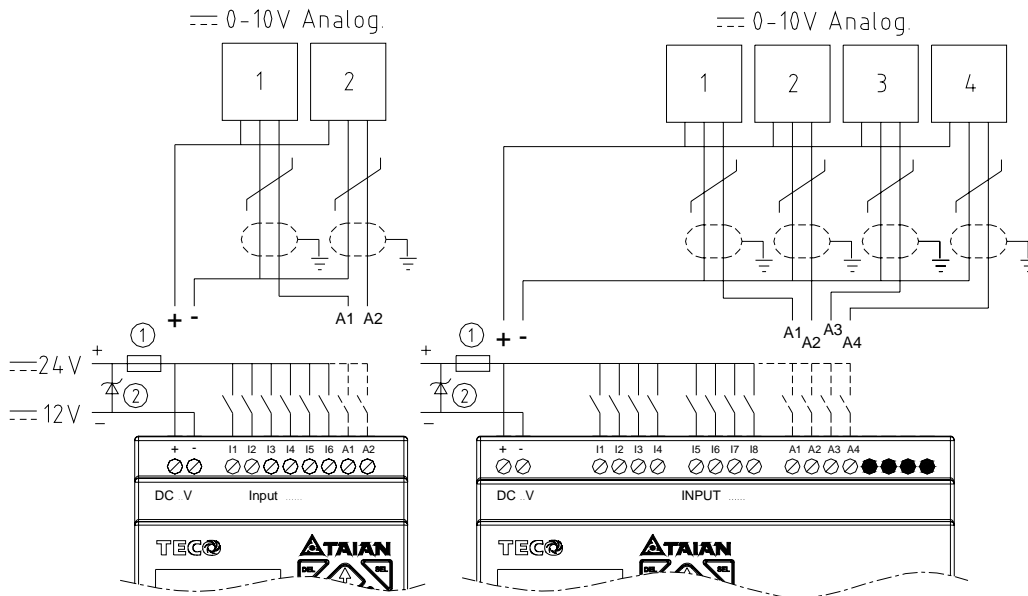

Sensor Connection

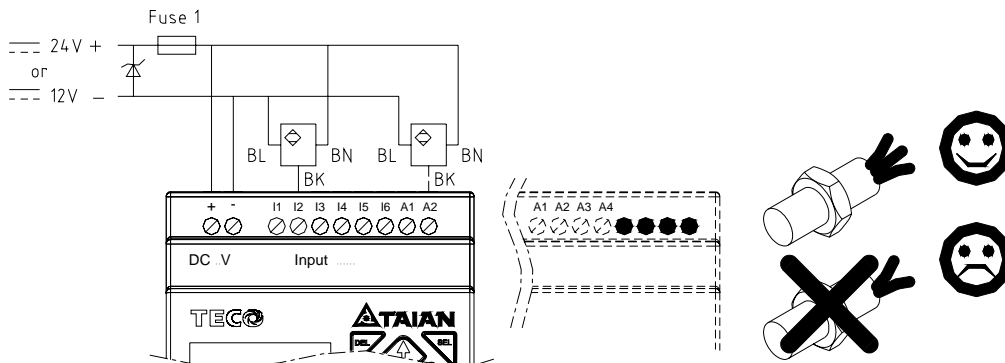

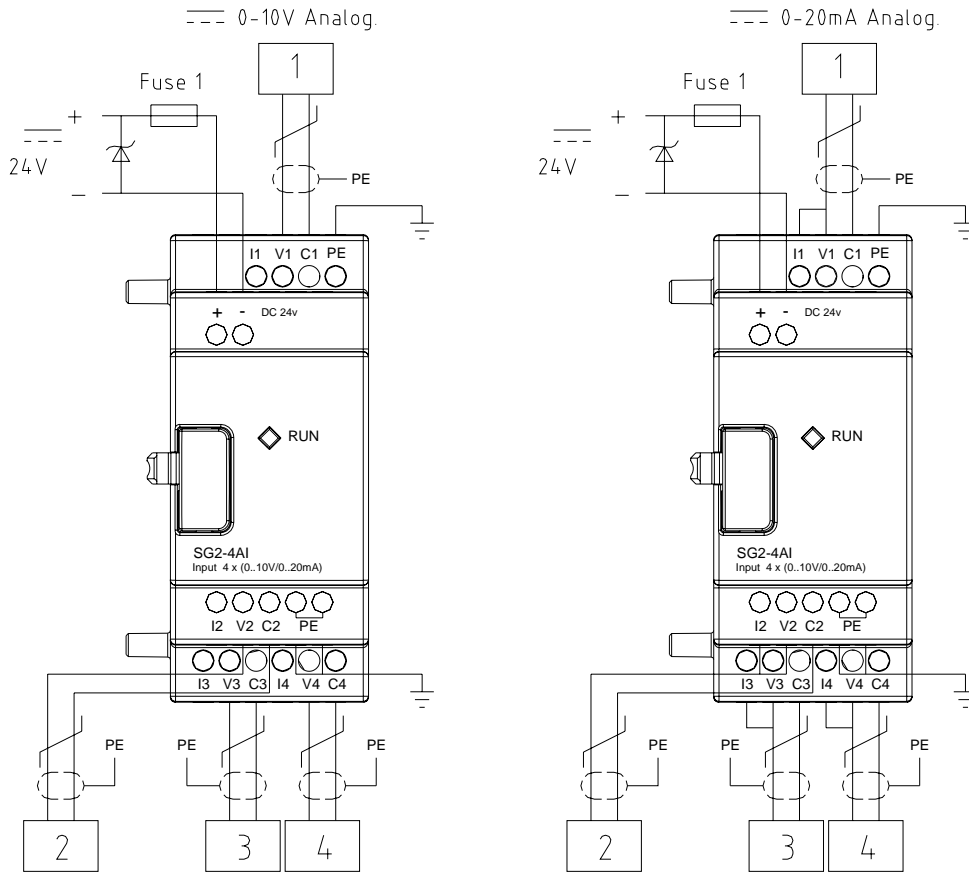

Input 100~240V /24V AC

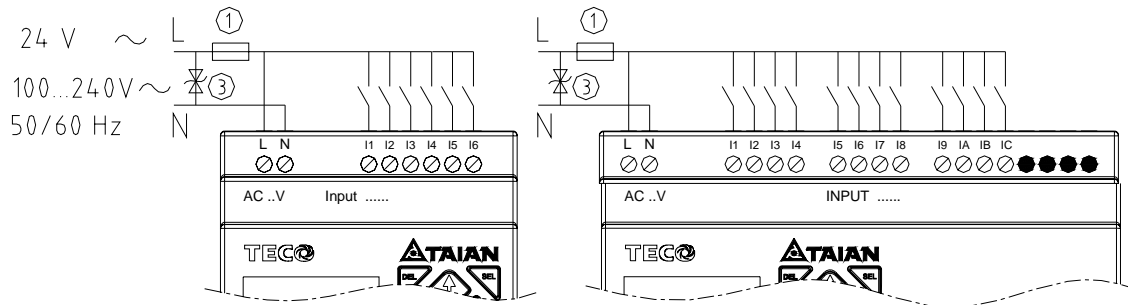

Output (Relay)

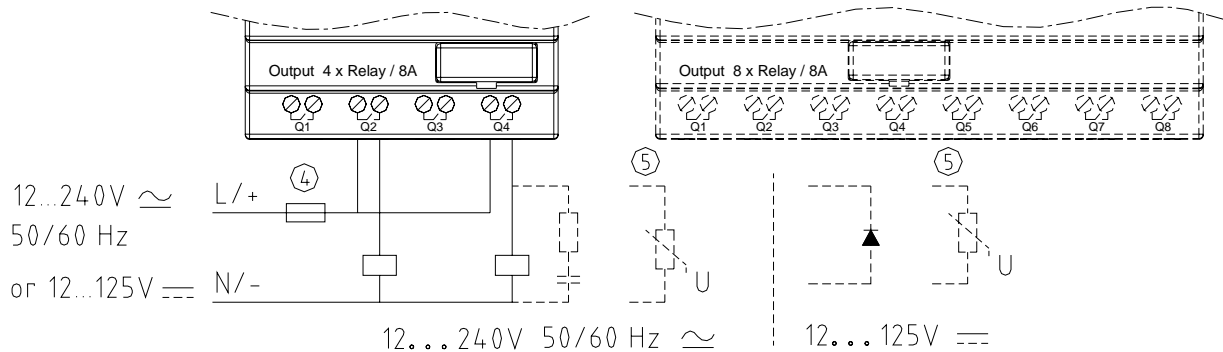

Output (Transistor)

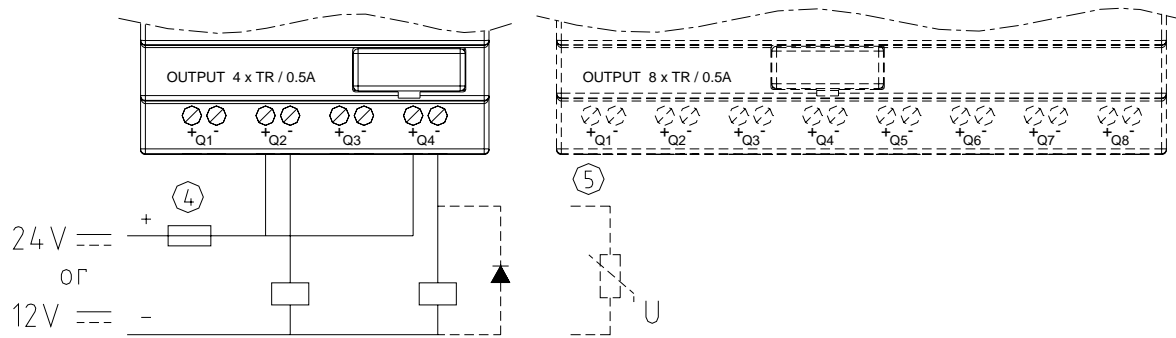

Data Link OR Remote I/O Link

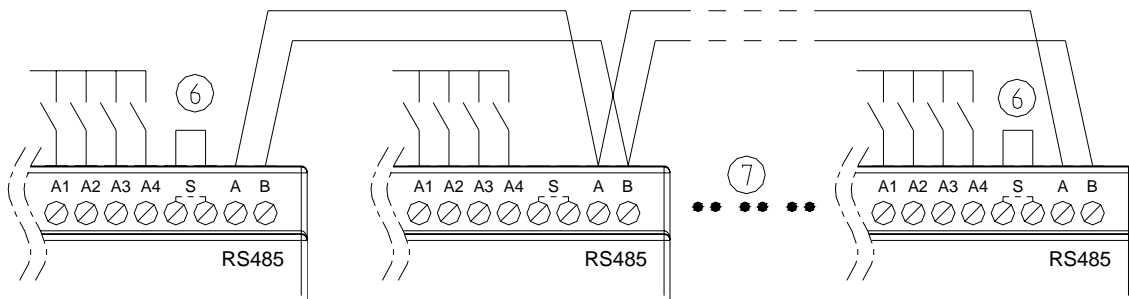

The power supply and the I/O supply should share the same power source. Only short circuit the first and the last module.

When I/O link, the net can connect 8 products in max. (ID: 0-7).

When Remote I/O is available, it only can connect 2 products max. (Master & Slave).

- 1A quick-blowing fuse, circuit-breaker or circuit protector
- Surge absorber (36V DC)
- Surge absorber (400V AC)
- Fuse, circuit-breaker or circuit protector
- Inductive load
- Only short circuit the first product and the last product
- Comply with standard : EIA RS-485.

Chapter 3: Program Tools

PC Programming Software “SG2 Client”

The SG2 Client programming software provides two edit modes, Ladder Logic and Function Block Diagram (FBD).

The SG2 Client software includes the following features:

1. Easy and convenient program creation and editing.
2. Programs can be saved on a computer for archiving and reuse. Programs can also be uploaded directly from an SG2 and saved or edited.
3. Enables users to print programs for reference and review.
4. The Simulation Mode allows users to run and test their program before it is loaded to the controller.
5. Real-time communication allows the user to monitor and force I/O on the SG2 smart relay operation during RUN mode.

Installing the Software

Install the SG2 Client Software from CD or from the free internet download at www.taian-technology.com



Connecting the Software

Remove the plastic connector cover from SG2 using a flathead screwdriver as shown in the figure below. Insert the plastic connector end of the programming cable into the SG2 smart relay as shown in the figure below. Connect the opposite end of the cable to an RS232C serial port on the computer.

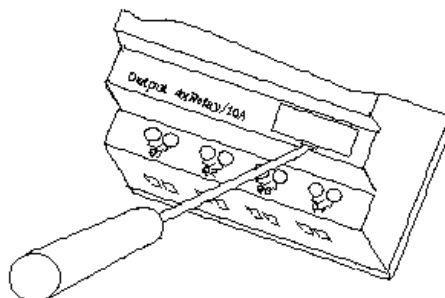

Start Screen

Run the SG2 Client software and the following Start screen will be displayed. From this screen, you can perform the following functions

New Ladder Program

Select File -->New -->New LAD to enter the development environment for a new Ladder program.

New FBD Program

Select File -->New -->New FBD to enter the development environment for a new FBD (Function Block Diagram) program.

Open Existing File

Select File -->Open to choose the type of file to open (Ladder or FBD), and choose the desired program file, and then click Open.



Ladder Logic Programming Environment

The Ladder Logic Programming Environment includes all the functions for programming and testing the SG2 using the Ladder Logic programming language. To begin a new program select File-->New--> and select the desired model of SG2, and the number of connected expansion units if applicable, as shown below.

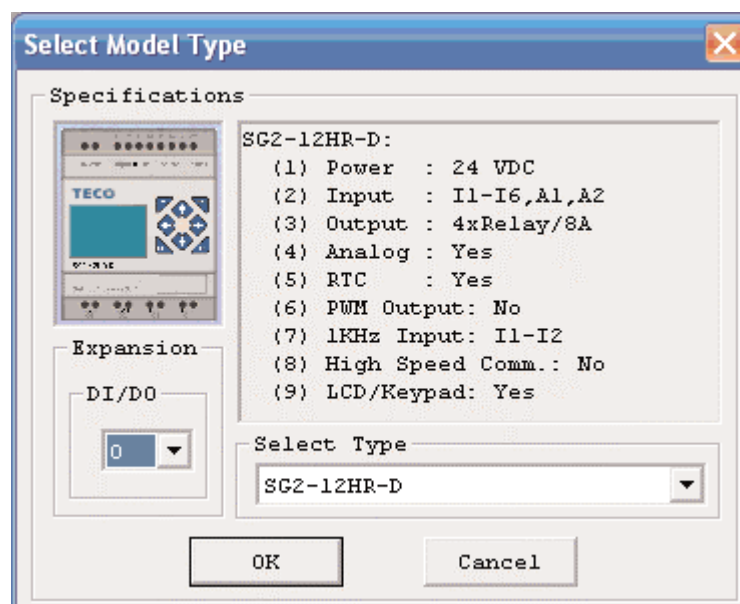

Menus, Icons and Status Displays

The Ladder programming environment includes the following Menus, Icons and Status Displays

1. Menu bar – Five menu selections for program development and retrieval, editing, communication to connected controllers, configuration of special functions and viewing preference selections.
2. Main Toolbar – (From Left to Right)
Icons for a new program, opening a program, saving a program and printing.
Icons for Keypad, Ladder view, HMI/Text editing and Symbol (comments) editing.
Icons for Monitor, Simulator, Controller Mode changes (Run, Stop, and Quit), and Read/Write programs to/from the SG2 smart relay.
3. Usage List – List for all memory types and addresses used with the current open program. Used addresses are designated by a "*" symbol below each address.
4. Amount of free programming memory available.
5. Current Mode – operation mode of the controller, or simulator, from the connected PC.
6. Ladder Toolbar – Icons for selecting and entering all available Ladder Logic instructions.
7. Status Bar – Status of current open project and connected SG2 smart relay.

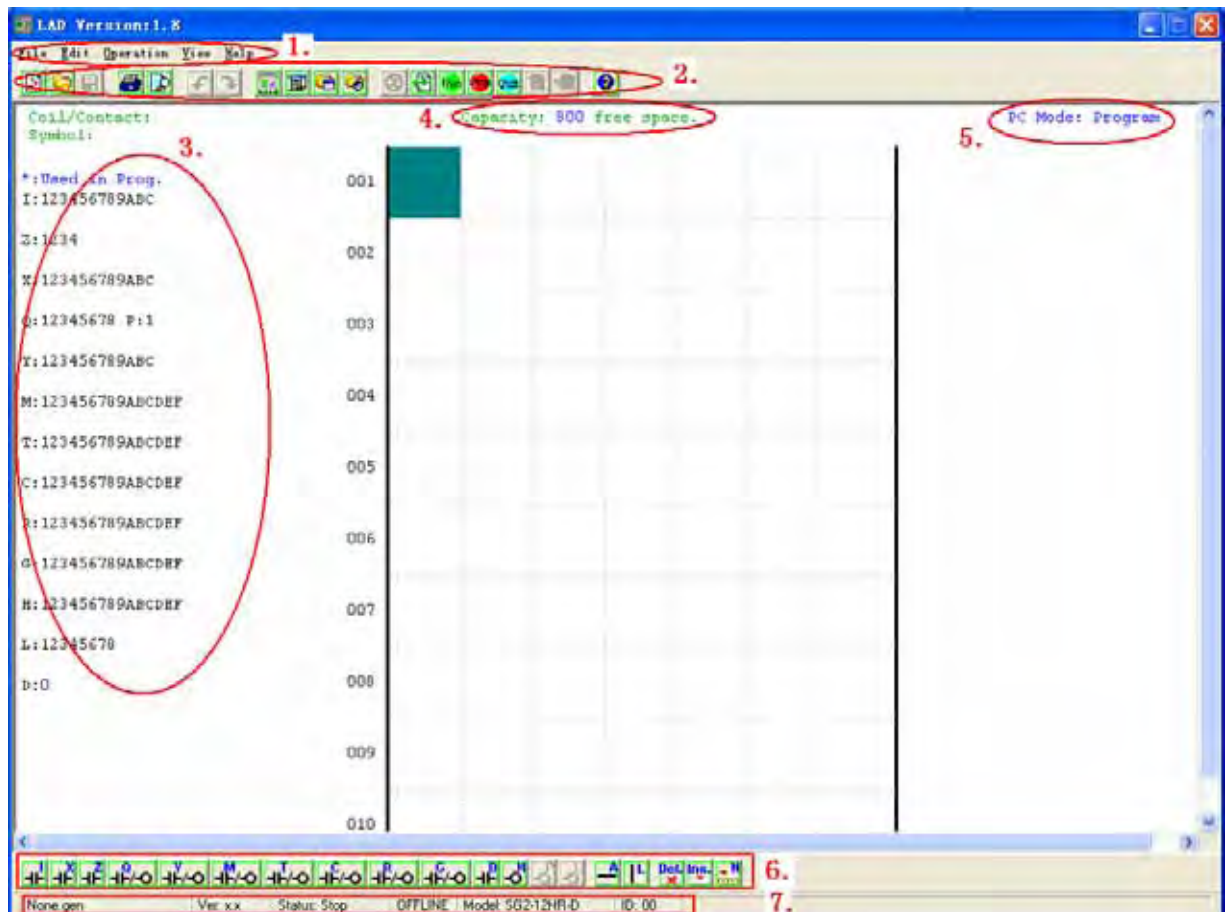

Programming

The SG2 Client software can be programmed by either drag-and-drop of instructions or by using keyboard entry commands. Below is an example of some common methods of entering programming instructions.

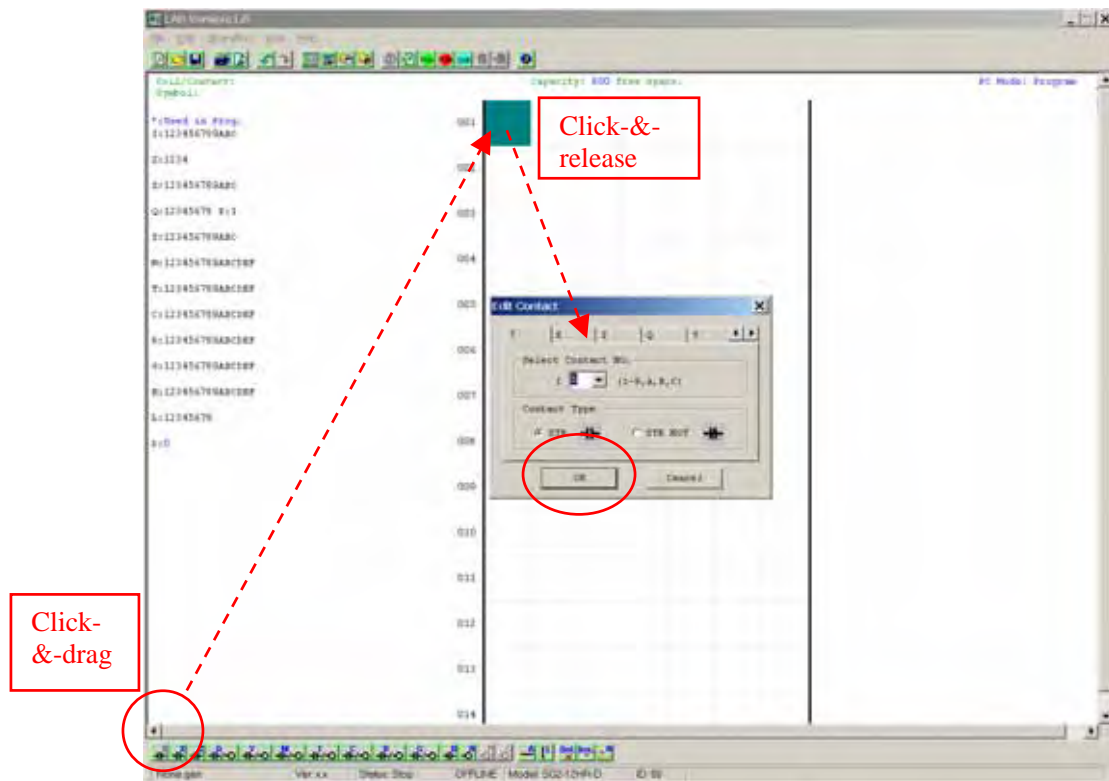

The "A" and "L" keys or icons are used to complete parallel and serial circuits. The rightmost column is for output coils.

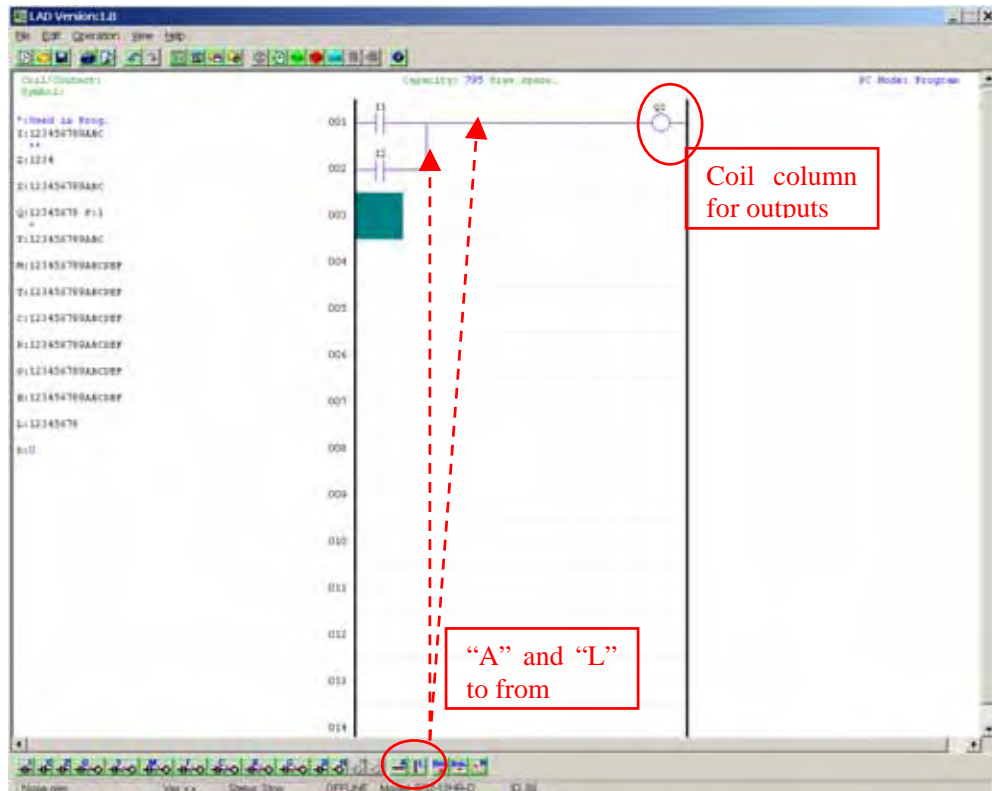

Simulation Mode

The SG2 Client software includes a built-in simulator to test and debug programs easily without the need for downloading to a controller. To activate simulation mode, simply press the red RUN icon. The program below is shown in simulation mode, identifying the significant available features.

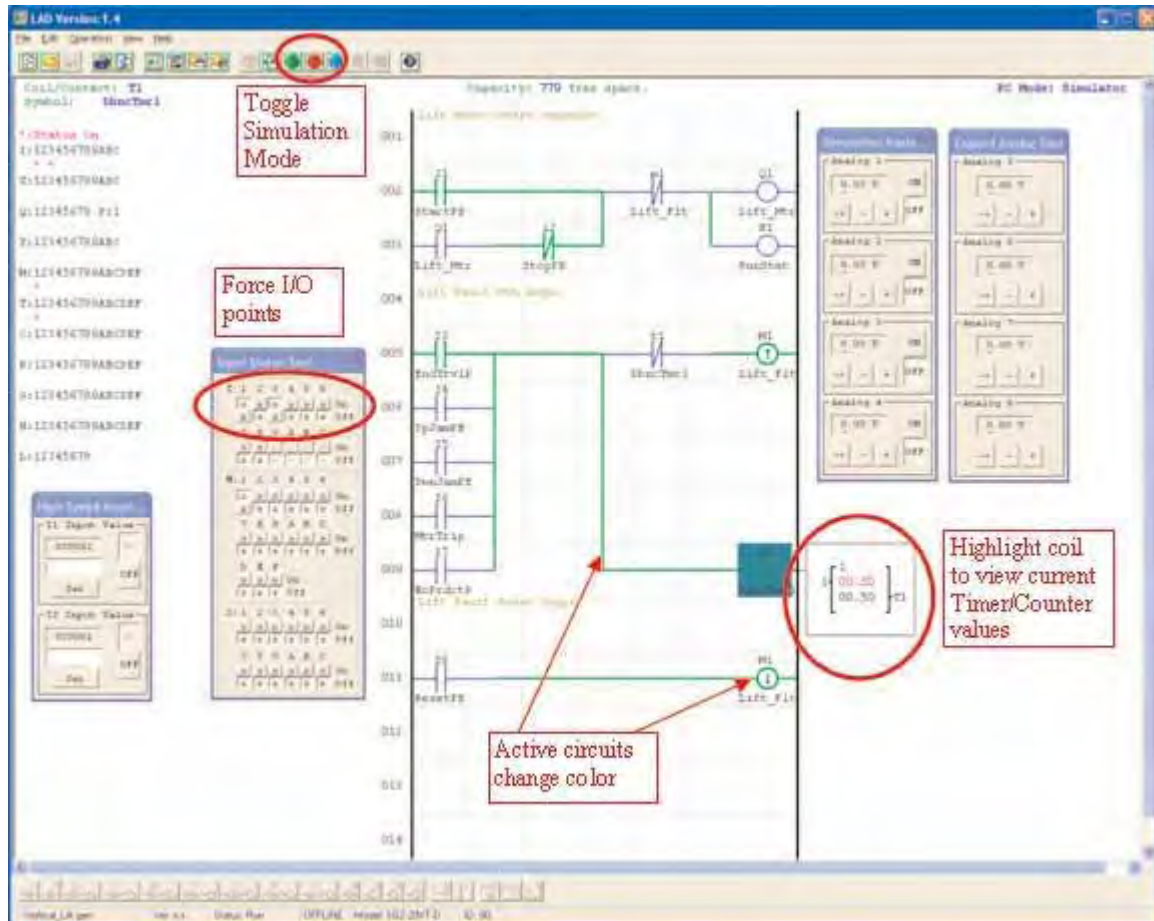

Establish Communication

The following is the simple procedure for establishing communication between the connected PC and the SG2 smart relay.

- Select "Operation/Link Com Port..." as shown below.

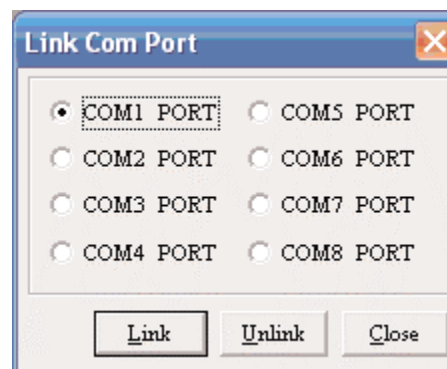
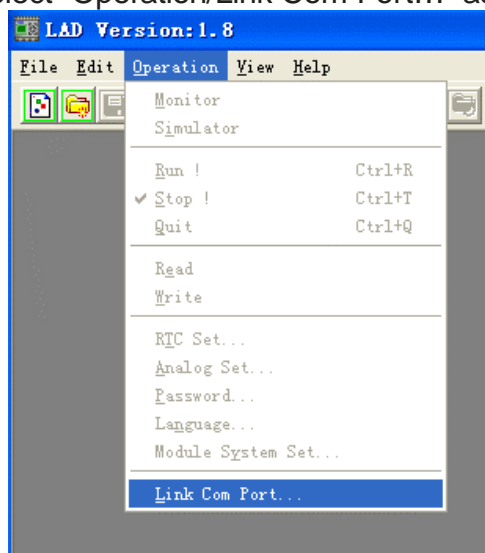

- b. Select the correct Com Port number where the programming cable is connected to the computer then press the “Link” button.
- c. The SG2 Client software will then begin to detect the connected smart relay to complete it's connection as shown below.

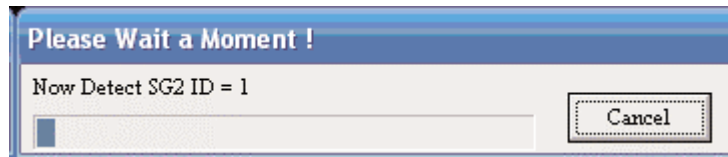

Writing Program to smart relay

From the Operation menu, select the Write function and write the program to the connected smart relay as shown below.

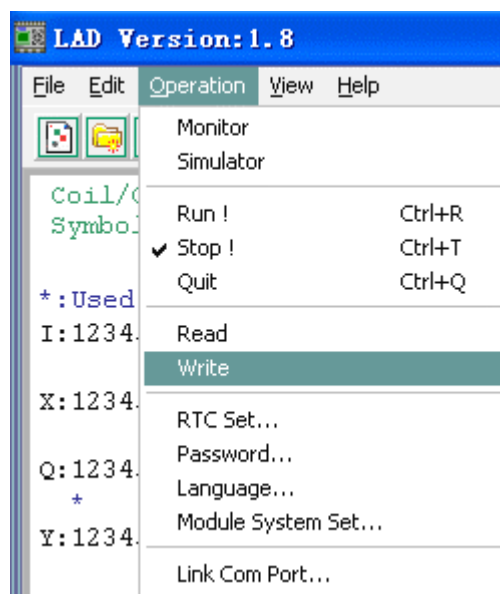

Operation menu

The Operation menu, includes several system configuration functions for both online and offline setup. The following explains the details of each function.

Monitor – Online function for runtime monitor and editing when connected to a controller

Simulator – Offline function for testing and debugging a program.

Run-Stop-Quit – Mode change selections for both runtime editing and simulation mode.

Read-Write – Reading and writing programs to and from a connected smart relay.

RTC Set – Online function for setup of the Real-time clock/calendar (see dialog below left)

Analog Set – setup analog input A1-A8 gain and offset (see dialog below right)

Password – Set a password for accessing the current program after upload to the smart relay

Language – Change software language

Module System Set – Dialog for changing important system setup functions including Module ID, Remote I/O preferences, Expansion I/O settings, and Retentive memory preferences (Keeping) for (C) Counters, (M) Auxiliary Coils, and (Z) keypad input set and the LCD Backlight.

RTC Set

Time Set

Week: WE

Hour:Minute 13 : 43

Year.Month.Day: 07 . 09 . 19

OK Cancel

Analog Display Set

A1 Gain (1~999): 10 Offset (-50~+50): 0

A2 Gain (1~999): 10 Offset (-50~+50): 0

A3 Gain (1~999): 10 Offset (-50~+50): 0

A4 Gain (1~999): 10 Offset (-50~+50): 0

A5 Gain (1~999): 10 Offset (-50~+50): 0

A6 Gain (1~999): 10 Offset (-50~+50): 0

A7 Gain (1~999): 10 Offset (-50~+50): 0

A8 Gain (1~999): 10 Offset (-50~+50): 0

OK Cancel

Online Monitoring/Editing

The SG2 Client software allows for online monitoring of the currently running program during runtime. Additional online functions include, I/O forcing, and Mode changes (Run/Stop/Quit).

Note: The SG2 Client software does not support runtime logic editing changes. All logic edits to contacts, coils, timers/counters, and circuit connecting lines must be written to the connected smart relay while in Stop mode.

The screenshot displays the SG2 Client software interface. The main window shows a ladder logic diagram with various components and connections. The interface includes a status bar at the bottom and a toolbar at the top. Several annotations are present:

- Toggle Run/Stop Mode:** A red circle highlights the Run/Stop button in the toolbar.
- Force I/O points:** A red circle highlights the 'Force I/O' button in the toolbar.
- Highlight coil to view current Timer/Counter values:** A red circle highlights a coil in the ladder logic diagram.
- Active circuits change color:** A red circle highlights a coil in the ladder logic diagram.
- Status Bar:** The status bar at the bottom displays: 'Filename, Firmware version, Mode, Online/Offline, SG2 Model, and ID#'. A red circle highlights the status bar.

Program Documentation

The SG2 Client software includes the ability to document a program using Symbols and Line Comments. Symbols are used to label each I/O address up to a length of 12 characters. Line Comments are used to document sections of a program. Each Line Comment can have up to 4 lines with each line containing up to 50 characters in length. Below are examples of entering Symbols and Line Comments.

Symbol

The Symbol editing environment can be accessed through the menu using the Edit>Symbol... selection or using the symbol icon on the main toolbar shown below.

The Symbol editing environment allows for documenting all the contact and coil memory types, and selecting display modes as shown below.

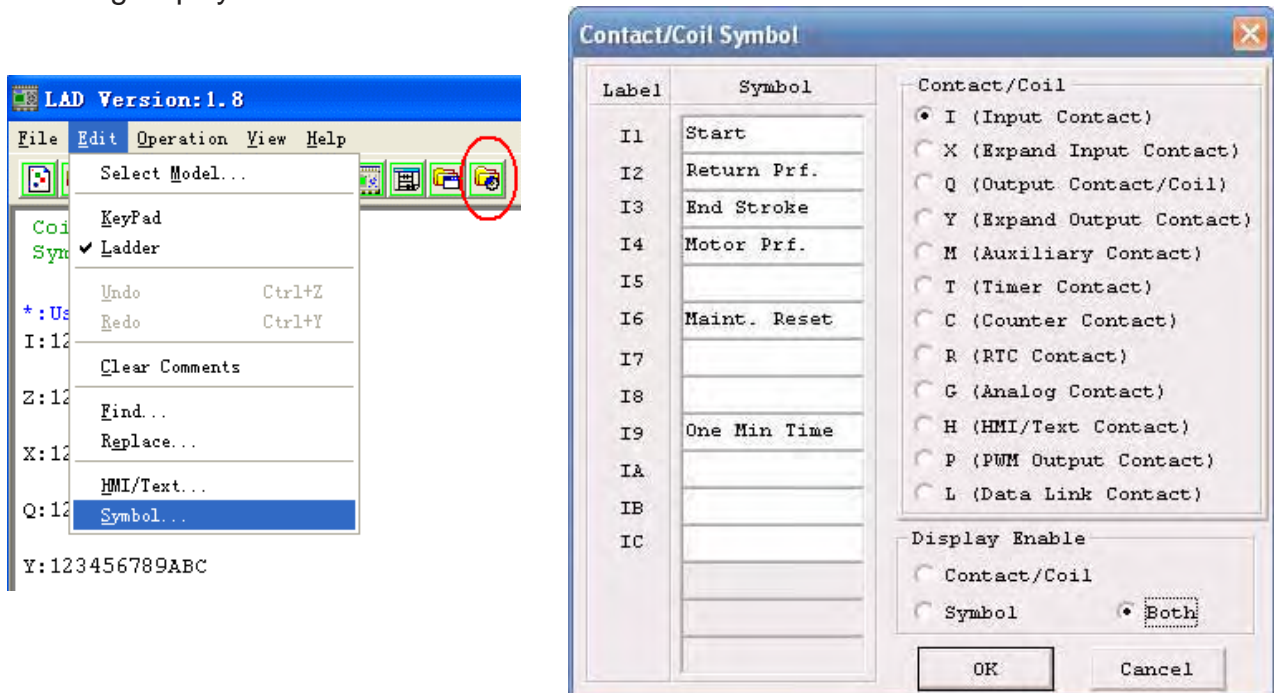

Line Comments

The Line Comment editor is accessed by clicking the "N" icon on the Ladder Toolbar. After clicking on the "N" icon, to drag the line number you want to comment and release, and then type the desired comments and press OK.

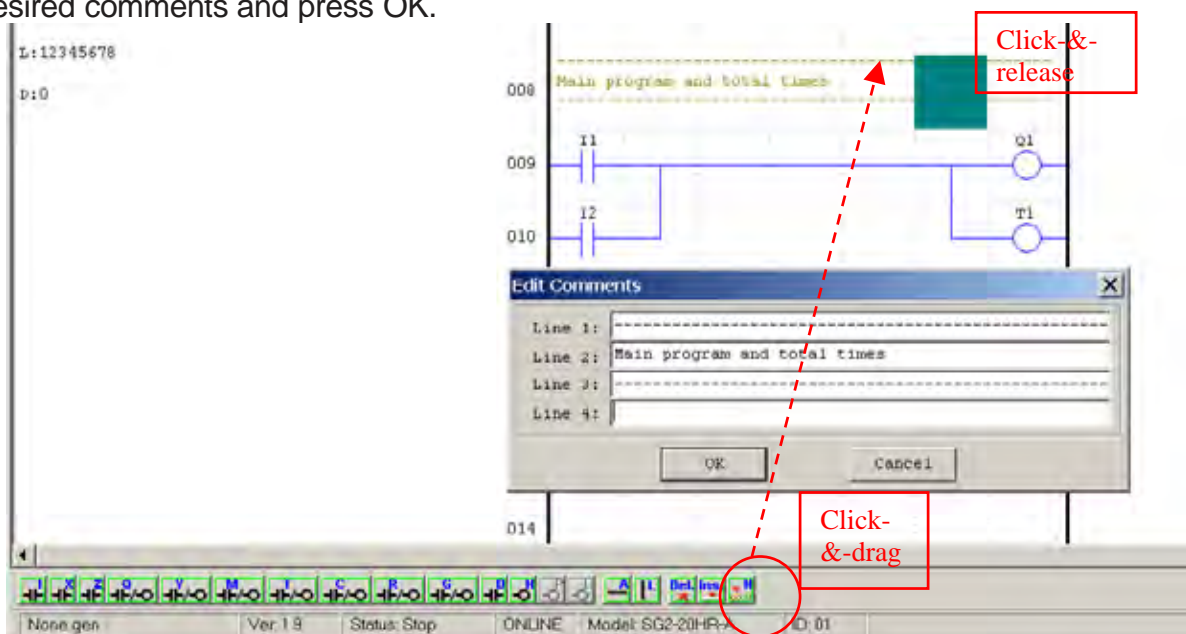

Memory Cartridge (sold separately)

The optional PM05 memory cartridge is used to easily transfer programs from one smart relay to another. The PM05 memory cartridge plugs into the same connector as the programming cable (see procedure below).

1. Remove the plastic connector cover from SG2 using a flathead screwdriver as shown in the figure above.
2. Insert the PM05 memory cartridge onto the connector as shown above.

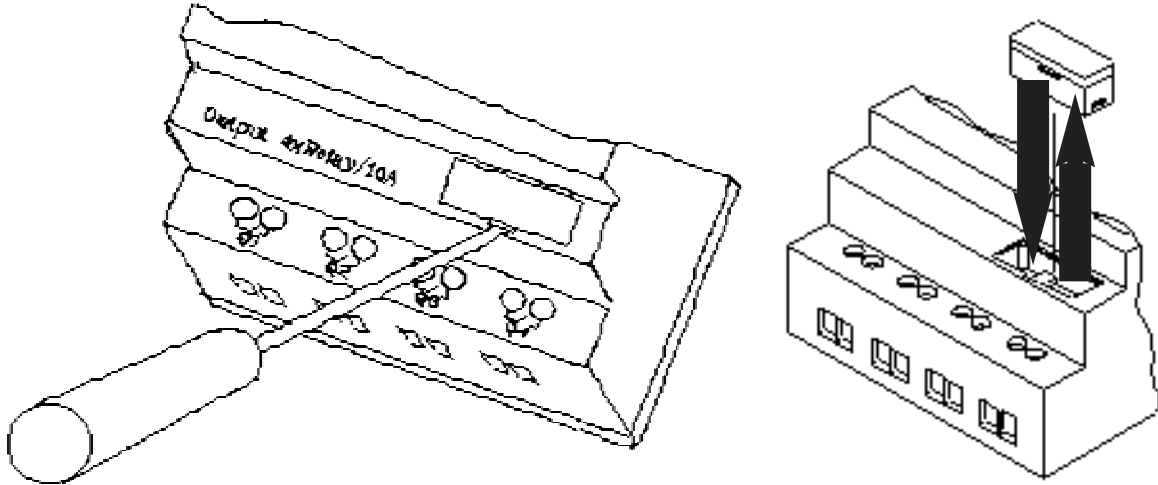

3. From the display keypad on the face of the SG2 smart relay, select either WRITE (to PM05) or READ (from PM05) to transfer the program to or from the smart relay to the PM05 memory cartridge.
4. K type and C type, electrify the product, the program in PM05 will automatically download and executed.
5. Program in different types are not compatible, here are the regulations:
 - A-1: 10/12 point type program ---- available in 20 point type
 - A-2: 20 point type program ---- unavailable in 10/12 point type
 - B-1: AC type program ---- available in DC type
 - B-2: DC type program ---- unavailable in AC type
 - C-1: Relay type program ---- available in Transistor type
 - C-2: Transistor type program ---- unavailable in Relay type
 - D-1: Not-V type program ---- available V type
 - D-2: V type program ---- unavailable Not-V type

LCD Display and Keypad

Keypad

Most SG2 CPU units include the built-in LCD Display and Keypad. The keypad and display are most often used for changing timer/counter set points, controller mode changes (Run/Stop), uploading/downloading to the PM05 memory cartridge, and updating the RTC (Real Time Clock/Calendar). Although, logic programming can be performed from the keypad and display, it is highly recommended to only perform logic changes using the SG2 Client software. Below is an overview of the basic keypad and display functions.

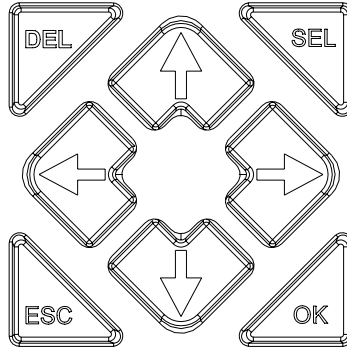

Select – Used to select the available memory and instruction types for editing. Holding the Select button will display all “H” HMI/Text messages on the LCD.

OK – Used to accept the selection displayed of an instruction or function. It is also used to select any of the Main Menu options on the LCD.

Note: Press the “SEL” and “OK” simultaneously to insert a rung above the current active cursor position.

Escape – Used to exit a selected display screen and go to the previous screen. When in a ladder display screen, press the ESC to display the main menu.

Delete – Used to delete an instruction or rung from the ladder program.

The 4 navigation buttons () are used to move the cursor throughout the functions of the SG2 display or active program. The 4 buttons also can be set programmable input coils Z1-Z4 (‘ ’= Z1, ‘ ’=Z2, ‘ ’=Z3, ‘ ’ =Z4);

LCD Display

Main Menu

LCD displays 4-line Main Menu

(1) The Main Menu as SG2 under ‘STOP’ Mode.

> LADDER	
FUN.BLOCK	
RUN	
CLEAR PROG.	→ Clear the user program and the password
WRITE	→ Save user program to PM05
READ	→ Read user Program from PM05
SET	
RTC SET	
ANALOG SET	
PASSWORD	
LANGUAGE	→ Select the language
INITIAL	→ initially set Edit method

(2) The Main Menu as SG2 under 'RUN' Mode.

>	LADDER
	FUN.BLOCK
	STOP
	WRITE
	RTC SET
	WRITE
	PASSWORD
	LANGUAGE

Press the Button

↑ ↓	Move the Cursor to select Main Menu
OK	Confirm the selected Function
ESC	Skip to Initial Screen

SG2 can be modified, edited, cleared and read user program only when it is under STOP Mode. As the program is modified, SG2 will automatically backup it to EEPROM. (Not PM05)

Main Menu LADDER

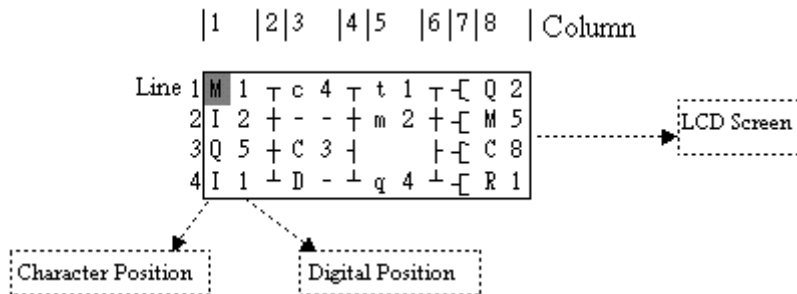

Press the Button

Button	Description
SEL	1. Ix ⇒ ix ⇒ — ⇒ space ⇒ Ix (only for digital and character position of 1,3,5 column.) 2. Qx ⇒ space ⇒ Qx (only for digital and character position of 8 column.). 3. T ⇒ Space ⇒ T (all available but the 2,4,6 column of the first line) x : Digital: 1~F
SEL + ↑/↓	1. 1...F, - (When the cursor locates the digital position, the range of digital is restricted by the relay type. 2. I ⇔ X ⇔ Z ⇔ Q ⇔ Y ⇔ M ⇔ D ⇔ T ⇔ C ⇔ R ⇔ G ⇔ I (When the cursor located at 1,3,5 Column). 3. Q ⇔ Y ⇔ M ⇔ T ⇔ C ⇔ R ⇔ G ⇔ H ⇔ L ⇔ P ⇔ Q (When the cursor located at 8 Column) 4. (⇔ ^ ⇔ v ⇔ P ⇔ ((When the cursor located at 7 Column, and the 8 Column is set as Q, Y, M) 5. (⇔ P ⇔ ((When the cursor located at 7 Column, and the 8 Column is set as T)
SEL + ←/→	Confirm the input data and move the cursor
↑/↓	Vertically move the cursor
←/→	Horizontally move the cursor
DEL	Delete an instruction
ESC	1. Cancel the Instruction or action under Edition. 2. Back to Main Menu after query the program.
OK	1. Confirm the data and automatically save, the cursor moves to next input position. 2. When the cursor is on Column 8, Press the button to automatically enter the function block and set the parameters(such as T/C).
SEL+DEL	Delete a Line of Instruction.
SEL+ESC	Display the number of the Lines and operation state of SG2 (RUN/STOP).
SEL+↑/↓	Skip up/ down every 4-line program.
SEL+OK	Insert a space line

operation Sample :

	1	2	3	4	5	6	7	8	Column
Line 1	>	L	A	D	D	E	R		
2		F	U	N	.	B	L	O	C
3		R	U	N					
4		C	L	E	A	R	P	R	O

	1	2	3	4	5	6	7	8	Column
Line 1									
2									
3									
4									

Procedure 1:
Press 'OK'

Enter LADDER Edition

	1	2	3	4	5	6	7	8	Column
Line 1	I	1							
2									
3									
4									

Procedure 2 :
Press 'SEL'

(When cursor located at character or digital, press the button to show I)

	1	2	3	4	5	6	7	8	Column
Line 1	Q	1							
2									
3									
4									

Procedure 3 :
Press '↑' 3 times

(Press 'SEL' + '↑↓', and the digital cursor located will change from I to Q).

	1	2	3	4	5	6	7	8	Column
Line 1	q	1							
2									
3									
4									

Procedure 4 :
Press 'SEL'

(start /end modifying parameter)

	1	2	3	4	5	6	7	8	Column
Line 1	q	1							
2									
3									
4									

Procedure 5 :
Press '→'

(“Press 'SEL' + '← →', the cursor located in digital)

	1	2	3	4	5	6	7	8	Column
Line 1	q	4							
2									
3									
4									

Procedure 6 :
Press '↑' for 3 times

(“Press 'SEL' + '↑↓' the digital the cursor located will change from 1 to 4)

	1	2	3	4	5	6	7	8	Column
Line 1	q	4							
2									
3									
4									

Procedure 7 :
Press '←'

(Press 'SEL' + '← →' to move the cursor to the position Required revision.

OR

Automatically Link

	1	2	3	4	5	6	7	8	Column
Procedure 7 : Press 'OK'	q	4	—						
(Move the cursor to character in column 3)									
Line 1									
2									
3									
4									

OR

Automatically Link

	1	2	3	4	5	6	7	8	Column
Procedure 7 : Press '→'	q	4	—						
(move the cursor to the link location in column 2)									
Line 1									
2									
3									
4									

Repeat the step1~7, and input M1, I3 Instruction to column 3, 5.

	1	2	3	4	5	6	7	8	Column
Procedure 8 : Press 'OK' in Column 5	q	4	—	M	1	—	I	3	—
(move the cursor to the character in column 8)									
Line 1									
2									
3									
4									

	1	2	3	4	5	6	7	8	Column
Procedure 9 : Press 'SEL'	q	4	—	M	1	—	I	3	—
(when the cursor located at character and digital, press 'SEL' to show '-(Q1)')									
Line 1									
2									
3									
4									

Auto Add “-(”

	1	2	3	4	5	6	7	8	Column
Procedure 10 : Press 'OK'	q	4	—	M	1	—	I	3	—
Save the input program data, the position of the cursor will not move.									
Line 1									
2									
3									
4									

	1	2	3	4	5	6	7	8	Column
Procedure 11 : Press '→' twice	q	4	—	M	1	—	I	3	—
(move the cursor to column 1 and Line 2.)									
Line 1									
2									
3									
4									

	1	2	3	4	5	6	7	8	Column
Procedure 12 : Press '→' twice	q	4	—	M	1	—	I	3	—
(move the cursor to column 2)									
Line 1									
2									
3									
4									

Note: never press 'SEL' before hand

Procedure : Press 'SEL+DEL' (Simultaneously) ('ESC' Cancel , 'OK' Execute)	<table border="1"> <thead> <tr> <th></th> <th>1</th> <th>2</th> <th>3</th> <th>4</th> <th>5</th> <th>6</th> <th>7</th> <th>8</th> <th>Column</th> </tr> </thead> <tbody> <tr> <td>Line 1</td> <td>q</td> <td>4</td> <td>T</td> <td>M</td> <td>1</td> <td>—</td> <td>I</td> <td>3</td> <td>— (Q 1</td> </tr> <tr> <td>2</td> <td></td> <td></td> <td>↓</td> <td>r</td> <td>3</td> <td>—</td> <td>—</td> <td>—</td> <td>(C 7</td> </tr> <tr> <td>3</td> <td>C</td> <td>L</td> <td>E</td> <td>A</td> <td>R</td> <td></td> <td>L</td> <td>n</td> <td>0 0 2</td> </tr> <tr> <td>4</td> <td>E</td> <td>S</td> <td>C</td> <td>?</td> <td></td> <td></td> <td>O</td> <td>K</td> <td>?</td> </tr> </tbody> </table>		1	2	3	4	5	6	7	8	Column	Line 1	q	4	T	M	1	—	I	3	— (Q 1	2			↓	r	3	—	—	—	(C 7	3	C	L	E	A	R		L	n	0 0 2	4	E	S	C	?			O	K	?
	1	2	3	4	5	6	7	8	Column																																										
Line 1	q	4	T	M	1	—	I	3	— (Q 1																																										
2			↓	r	3	—	—	—	(C 7																																										
3	C	L	E	A	R		L	n	0 0 2																																										
4	E	S	C	?			O	K	?																																										

Insert a whole line.

	<table border="1"> <thead> <tr> <th></th> <th>1</th> <th>2</th> <th>3</th> <th>4</th> <th>5</th> <th>6</th> <th>7</th> <th>8</th> <th>column</th> </tr> </thead> <tbody> <tr> <td>line 1</td> <td>q</td> <td>4</td> <td>T</td> <td>M</td> <td>1</td> <td>—</td> <td>I</td> <td>3</td> <td>— (Q 1</td> </tr> <tr> <td>2</td> <td></td> <td></td> <td>↓</td> <td>r</td> <td>3</td> <td>—</td> <td>—</td> <td>—</td> <td>(C 7</td> </tr> <tr> <td>3</td> <td></td> <td></td> <td></td> <td></td> <td></td> <td></td> <td></td> <td></td> <td></td> </tr> <tr> <td>4</td> <td></td> <td></td> <td></td> <td></td> <td></td> <td></td> <td></td> <td></td> <td></td> </tr> </tbody> </table>		1	2	3	4	5	6	7	8	column	line 1	q	4	T	M	1	—	I	3	— (Q 1	2			↓	r	3	—	—	—	(C 7	3										4									
	1	2	3	4	5	6	7	8	column																																										
line 1	q	4	T	M	1	—	I	3	— (Q 1																																										
2			↓	r	3	—	—	—	(C 7																																										
3																																																			
4																																																			

Step: Press "SEL+OK" (at the same time)	<table border="1"> <thead> <tr> <th></th> <th>1</th> <th>2</th> <th>3</th> <th>4</th> <th>5</th> <th>6</th> <th>7</th> <th>8</th> <th>column</th> </tr> </thead> <tbody> <tr> <td>Line 1</td> <td>q</td> <td>4</td> <td>T</td> <td>M</td> <td>1</td> <td>—</td> <td>I</td> <td>3</td> <td>— (Q 1</td> </tr> <tr> <td>2</td> <td></td> <td></td> <td>↓</td> <td>r</td> <td>3</td> <td>—</td> <td>—</td> <td>—</td> <td>(C 7</td> </tr> <tr> <td>3</td> <td></td> <td></td> <td></td> <td></td> <td></td> <td></td> <td></td> <td></td> <td></td> </tr> <tr> <td>4</td> <td></td> <td></td> <td></td> <td></td> <td></td> <td></td> <td></td> <td></td> <td></td> </tr> </tbody> </table>		1	2	3	4	5	6	7	8	column	Line 1	q	4	T	M	1	—	I	3	— (Q 1	2			↓	r	3	—	—	—	(C 7	3										4									
	1	2	3	4	5	6	7	8	column																																										
Line 1	q	4	T	M	1	—	I	3	— (Q 1																																										
2			↓	r	3	—	—	—	(C 7																																										
3																																																			
4																																																			

Turn page (move upward/ downward 4 lines program) :

	<table border="1"> <thead> <tr> <th></th> <th>1</th> <th>2</th> <th>3</th> <th>4</th> <th>5</th> <th>6</th> <th>7</th> <th>8</th> <th>column</th> </tr> </thead> <tbody> <tr> <td>line 1</td> <td>q</td> <td>4</td> <td>T</td> <td>M</td> <td>1</td> <td>—</td> <td>I</td> <td>3</td> <td>— (Q 1</td> </tr> <tr> <td>2</td> <td></td> <td></td> <td>↓</td> <td>r</td> <td>3</td> <td>—</td> <td>—</td> <td>—</td> <td>(C 7</td> </tr> <tr> <td>3</td> <td></td> <td></td> <td></td> <td></td> <td></td> <td></td> <td></td> <td></td> <td></td> </tr> <tr> <td>4</td> <td></td> <td></td> <td></td> <td></td> <td></td> <td></td> <td></td> <td></td> <td></td> </tr> <tr> <td>5</td> <td></td> <td></td> <td></td> <td></td> <td></td> <td></td> <td></td> <td></td> <td></td> </tr> </tbody> </table>		1	2	3	4	5	6	7	8	column	line 1	q	4	T	M	1	—	I	3	— (Q 1	2			↓	r	3	—	—	—	(C 7	3										4										5									
	1	2	3	4	5	6	7	8	column																																																				
line 1	q	4	T	M	1	—	I	3	— (Q 1																																																				
2			↓	r	3	—	—	—	(C 7																																																				
3																																																													
4																																																													
5																																																													

Step : Press 'SEL+↑↓' (at the same time)	<table border="1"> <thead> <tr> <th></th> <th>1</th> <th>2</th> <th>3</th> <th>4</th> <th>5</th> <th>6</th> <th>7</th> <th>8</th> <th>column</th> </tr> </thead> <tbody> <tr> <td>line 1</td> <td>q</td> <td>4</td> <td>T</td> <td>M</td> <td>1</td> <td>—</td> <td>I</td> <td>3</td> <td>— (Q 1</td> </tr> <tr> <td>2</td> <td></td> <td></td> <td>↓</td> <td>r</td> <td>3</td> <td>—</td> <td>—</td> <td>—</td> <td>(C 7</td> </tr> <tr> <td>3</td> <td></td> <td></td> <td></td> <td></td> <td></td> <td></td> <td></td> <td></td> <td></td> </tr> <tr> <td>4</td> <td></td> <td></td> <td></td> <td></td> <td></td> <td></td> <td></td> <td></td> <td></td> </tr> <tr> <td>5</td> <td></td> <td></td> <td></td> <td></td> <td></td> <td></td> <td></td> <td></td> <td></td> </tr> </tbody> </table>		1	2	3	4	5	6	7	8	column	line 1	q	4	T	M	1	—	I	3	— (Q 1	2			↓	r	3	—	—	—	(C 7	3										4										5									
	1	2	3	4	5	6	7	8	column																																																				
line 1	q	4	T	M	1	—	I	3	— (Q 1																																																				
2			↓	r	3	—	—	—	(C 7																																																				
3																																																													
4																																																													
5																																																													

FUNCTION BLOCK program input

	<table border="1"> <thead> <tr> <th></th> <th>1</th> <th>2</th> <th>3</th> <th>4</th> <th>5</th> <th>6</th> <th>7</th> <th>8</th> <th>Column</th> </tr> </thead> <tbody> <tr> <td>Line 1</td> <td></td> <td>L</td> <td>A</td> <td>D</td> <td>D</td> <td>E</td> <td>R</td> <td></td> <td></td> </tr> <tr> <td>2</td> <td>></td> <td>F</td> <td>U</td> <td>N</td> <td>.</td> <td>B</td> <td>L</td> <td>O</td> <td>C</td> </tr> <tr> <td>3</td> <td></td> <td>R</td> <td>U</td> <td>N</td> <td></td> <td></td> <td></td> <td></td> <td></td> </tr> <tr> <td>4</td> <td></td> <td>C</td> <td>L</td> <td>E</td> <td>A</td> <td>R</td> <td>P</td> <td>R</td> <td>O</td> </tr> </tbody> </table>		1	2	3	4	5	6	7	8	Column	Line 1		L	A	D	D	E	R			2	>	F	U	N	.	B	L	O	C	3		R	U	N						4		C	L	E	A	R	P	R	O
	1	2	3	4	5	6	7	8	Column																																										
Line 1		L	A	D	D	E	R																																												
2	>	F	U	N	.	B	L	O	C																																										
3		R	U	N																																															
4		C	L	E	A	R	P	R	O																																										

Present action area
 The present value will appear when SG2 is under 'RUN' mode.

Procedure 1: Press 'OK' (Enter FUNCTION BLOCK edition)	<table border="1"> <thead> <tr> <th></th> <th>1</th> <th>2</th> <th>3</th> <th>4</th> <th>5</th> <th>6</th> <th>7</th> <th>8</th> <th>Column</th> </tr> </thead> <tbody> <tr> <td>Line 1</td> <td></td> <td></td> <td></td> <td></td> <td></td> <td></td> <td></td> <td></td> <td></td> </tr> <tr> <td>2</td> <td>1</td> <td>[</td> <td>1</td> <td>]</td> <td></td> <td></td> <td></td> <td></td> <td>T 1</td> </tr> <tr> <td>3</td> <td></td> <td></td> <td>0</td> <td>0</td> <td>0</td> <td>0</td> <td></td> <td></td> <td></td> </tr> <tr> <td>4</td> <td></td> <td></td> <td></td> <td></td> <td></td> <td></td> <td></td> <td></td> <td></td> </tr> </tbody> </table>		1	2	3	4	5	6	7	8	Column	Line 1										2	1	[1]					T 1	3			0	0	0	0				4									
	1	2	3	4	5	6	7	8	Column																																										
Line 1																																																			
2	1	[1]					T 1																																										
3			0	0	0	0																																													
4																																																			

Preset action value area

Never press '→' to move to the digital position. (If T2 is required to be changed, Press '↑'/'↓' and 'SEL' to execute.)	1	2	3	4	5	6	7	8	Column
	Line 1		1						
	2	1							
	3		0	0	.	0	0		T 1
4									

Step 2: modify ① present target value ② preset the action relay

Preset the target value

Procedure 2-1: Press '←' (move the cursor to the preset action area)	1	2	3	4	5	6	7	8	Column
	Line 1		1						
	2	1							
	3		0	0	.	0	0		T 1
4									

Procedure 2-2: Press 'SEL' (begin input the target value)	1	2	3	4	5	6	7	8	Column
	Line 1		1						
	2	1							
	3		0	0	.	0	<u>0</u>		T 1
4									

Procedure 2-3: Press '↑' for 3 times (Press 'SEL' and followed by '↑,↓' The digital '0' is changed to '3')	1	2	3	4	5	6	7	8	Column
	Line 1		1						
	2	1							
	3		0	0	.	0	<u>3</u>		T 1
4									

Procedure 2-4: Press 'OK' (Save the input data)	1	2	3	4	5	6	7	8	Column
	Line 1		1						
	2	1							
	3		0	0	.	0	3		T 1
4									

Procedure 2-5: Press '←'	1	2	3	4	5	6	7	8	Column
	Line 1		1						
	2	1							
	3		0	0	.	0	3		T 1
4									

Repeat Step 2-2 ~ step 2-4 for 3 times, to enter the following screen:

Procedure 2-6:	1	2	3	4	5	6	7	8	Column
	Line 1		1						
	2	1							
	3		3	3	.	3	3		T 1
4									

As the present value of the timer, counter, analog input (A1-A8) and analog gain value (V1-V8) is set as the preset value of them. Next to the step 2-2, to execute the following operation:

Step2-3A: Press 'SEL'	<table border="1"> <tr> <td></td> <td>1</td> <td>2</td> <td>3</td> <td>4</td> <td>5</td> <td>6</td> <td>7</td> <td>8</td> <td>column</td> </tr> <tr> <td>line</td> <td>1</td> <td></td> <td>1</td> <td></td> <td></td> <td></td> <td></td> <td></td> <td></td> </tr> <tr> <td></td> <td>1</td> <td> </td> <td></td> <td></td> <td></td> <td></td> <td></td> <td></td> <td></td> </tr> <tr> <td></td> <td></td> <td> </td> <td>V</td> <td><u>1</u></td> <td></td> <td></td> <td></td> <td></td> <td>T 1</td> </tr> <tr> <td></td> <td></td> <td> </td> <td></td> <td></td> <td></td> <td></td> <td></td> <td></td> <td></td> </tr> <tr> <td></td> <td>4</td> <td> </td> <td></td> <td></td> <td></td> <td></td> <td></td> <td></td> <td></td> </tr> </table>		1	2	3	4	5	6	7	8	column	line	1		1								1												V	<u>1</u>					T 1												4								
	1	2	3	4	5	6	7	8	column																																																				
line	1		1																																																										
	1																																																												
			V	<u>1</u>					T 1																																																				
	4																																																												

Repeat the step 2-3A, the following screen will be shown in turn:

Step2-3B: Press 'SEL'	<table border="1"> <tr> <td></td> <td>1</td> <td>2</td> <td>3</td> <td>4</td> <td>5</td> <td>6</td> <td>7</td> <td>8</td> <td>column</td> </tr> <tr> <td>line</td> <td>1</td> <td></td> <td>1</td> <td></td> <td></td> <td></td> <td></td> <td></td> <td></td> </tr> <tr> <td></td> <td>1</td> <td> </td> <td></td> <td></td> <td></td> <td></td> <td></td> <td></td> <td></td> </tr> <tr> <td></td> <td></td> <td> </td> <td>A</td> <td><u>1</u></td> <td></td> <td></td> <td></td> <td></td> <td>T 1</td> </tr> <tr> <td></td> <td></td> <td> </td> <td></td> <td></td> <td></td> <td></td> <td></td> <td></td> <td></td> </tr> <tr> <td></td> <td>4</td> <td> </td> <td></td> <td></td> <td></td> <td></td> <td></td> <td></td> <td></td> </tr> </table>		1	2	3	4	5	6	7	8	column	line	1		1								1												A	<u>1</u>					T 1												4								
	1	2	3	4	5	6	7	8	column																																																				
line	1		1																																																										
	1																																																												
			A	<u>1</u>					T 1																																																				
	4																																																												

Step 2-3C: press 'SEL'	<table border="1"> <tr> <td></td> <td>1</td> <td>2</td> <td>3</td> <td>4</td> <td>5</td> <td>6</td> <td>7</td> <td>8</td> <td>column</td> </tr> <tr> <td>line</td> <td>1</td> <td></td> <td>1</td> <td></td> <td></td> <td></td> <td></td> <td></td> <td></td> </tr> <tr> <td></td> <td>1</td> <td> </td> <td></td> <td></td> <td></td> <td></td> <td></td> <td></td> <td></td> </tr> <tr> <td></td> <td></td> <td> </td> <td>T</td> <td><u>1</u></td> <td></td> <td></td> <td></td> <td></td> <td>T 1</td> </tr> <tr> <td></td> <td></td> <td> </td> <td></td> <td></td> <td></td> <td></td> <td></td> <td></td> <td></td> </tr> <tr> <td></td> <td>4</td> <td> </td> <td></td> <td></td> <td></td> <td></td> <td></td> <td></td> <td></td> </tr> </table>		1	2	3	4	5	6	7	8	column	line	1		1								1												T	<u>1</u>					T 1												4								
	1	2	3	4	5	6	7	8	column																																																				
line	1		1																																																										
	1																																																												
			T	<u>1</u>					T 1																																																				
	4																																																												

Step 2-3D: Press 'SEL'	<table border="1"> <tr> <td></td> <td>1</td> <td>2</td> <td>3</td> <td>4</td> <td>5</td> <td>6</td> <td>7</td> <td>8</td> <td>column</td> </tr> <tr> <td>line</td> <td>1</td> <td></td> <td>1</td> <td></td> <td></td> <td></td> <td></td> <td></td> <td></td> </tr> <tr> <td></td> <td>1</td> <td> </td> <td></td> <td></td> <td></td> <td></td> <td></td> <td></td> <td></td> </tr> <tr> <td></td> <td></td> <td> </td> <td>C</td> <td><u>1</u></td> <td></td> <td></td> <td></td> <td></td> <td>T 1</td> </tr> <tr> <td></td> <td></td> <td> </td> <td></td> <td></td> <td></td> <td></td> <td></td> <td></td> <td></td> </tr> <tr> <td></td> <td>4</td> <td> </td> <td></td> <td></td> <td></td> <td></td> <td></td> <td></td> <td></td> </tr> </table>		1	2	3	4	5	6	7	8	column	line	1		1								1												C	<u>1</u>					T 1												4								
	1	2	3	4	5	6	7	8	column																																																				
line	1		1																																																										
	1																																																												
			C	<u>1</u>					T 1																																																				
	4																																																												

Next to step 2-3B, then '↑', the following screen will be shown.

step 2-4A: Press '↑'	<table border="1"> <tr> <td></td> <td>1</td> <td>2</td> <td>3</td> <td>4</td> <td>5</td> <td>6</td> <td>7</td> <td>8</td> <td>column</td> </tr> <tr> <td>line</td> <td>1</td> <td></td> <td>1</td> <td></td> <td></td> <td></td> <td></td> <td></td> <td></td> </tr> <tr> <td></td> <td>1</td> <td> </td> <td></td> <td></td> <td></td> <td></td> <td></td> <td></td> <td></td> </tr> <tr> <td></td> <td></td> <td> </td> <td>A</td> <td><u>2</u></td> <td></td> <td></td> <td></td> <td></td> <td>T 1</td> </tr> <tr> <td></td> <td></td> <td> </td> <td></td> <td></td> <td></td> <td></td> <td></td> <td></td> <td></td> </tr> <tr> <td></td> <td>4</td> <td> </td> <td></td> <td></td> <td></td> <td></td> <td></td> <td></td> <td></td> </tr> </table>		1	2	3	4	5	6	7	8	column	line	1		1								1												A	<u>2</u>					T 1												4								
	1	2	3	4	5	6	7	8	column																																																				
line	1		1																																																										
	1																																																												
			A	<u>2</u>					T 1																																																				
	4																																																												

Repeat step2-4A (press '↓' is also available) , the preset value of A1-A8 will be periodically changed. And so on. 'Analog*gain + offset' value (V1-V8) and the other function blocks (time, counter) present value is set as preset value, to repeat the step to select T1-TF, C1-CF, V1-V8.

step 2-5A: press 'OK'	<table border="1"> <tr> <td></td> <td>1</td> <td>2</td> <td>3</td> <td>4</td> <td>5</td> <td>6</td> <td>7</td> <td>8</td> <td>column</td> </tr> <tr> <td>line</td> <td>1</td> <td></td> <td>1</td> <td></td> <td></td> <td></td> <td></td> <td></td> <td></td> </tr> <tr> <td></td> <td>1</td> <td> </td> <td></td> <td></td> <td></td> <td></td> <td></td> <td></td> <td></td> </tr> <tr> <td></td> <td></td> <td> </td> <td>A</td> <td><u>2</u></td> <td></td> <td></td> <td></td> <td></td> <td>T 1</td> </tr> <tr> <td></td> <td></td> <td> </td> <td></td> <td></td> <td></td> <td></td> <td></td> <td></td> <td></td> </tr> <tr> <td></td> <td>4</td> <td> </td> <td></td> <td></td> <td></td> <td></td> <td></td> <td></td> <td></td> </tr> </table>		1	2	3	4	5	6	7	8	column	line	1		1								1												A	<u>2</u>					T 1												4								
	1	2	3	4	5	6	7	8	column																																																				
line	1		1																																																										
	1																																																												
			A	<u>2</u>					T 1																																																				
	4																																																												

Save the present data.

Procedure 2-7: Press '↑'	<table border="1"> <tr> <td></td> <td>1</td> <td>2</td> <td>3</td> <td>4</td> <td>5</td> <td>6</td> <td>7</td> <td>8</td> <td>Column</td> </tr> <tr> <td>Line</td> <td>1</td> <td></td> <td>1</td> <td></td> <td></td> <td></td> <td></td> <td></td> <td></td> </tr> <tr> <td></td> <td><u>1</u></td> <td> </td> <td></td> <td></td> <td></td> <td></td> <td></td> <td></td> <td></td> </tr> <tr> <td></td> <td></td> <td> </td> <td>3</td> <td>3</td> <td>.</td> <td>3</td> <td>3</td> <td></td> <td>T 1</td> </tr> <tr> <td></td> <td></td> <td> </td> <td></td> <td></td> <td></td> <td></td> <td></td> <td></td> <td></td> </tr> <tr> <td></td> <td>4</td> <td> </td> <td></td> <td></td> <td></td> <td></td> <td></td> <td></td> <td></td> </tr> </table>		1	2	3	4	5	6	7	8	Column	Line	1		1								<u>1</u>												3	3	.	3	3		T 1												4								
	1	2	3	4	5	6	7	8	Column																																																				
Line	1		1																																																										
	<u>1</u>																																																												
			3	3	.	3	3		T 1																																																				
	4																																																												

Procedure 2-8: Press 'SEL'	<table border="1"> <tr> <td></td> <td>1</td> <td>2</td> <td>3</td> <td>4</td> <td>5</td> <td>6</td> <td>7</td> <td>8</td> <td>Column</td> </tr> <tr> <td>Line</td> <td>1</td> <td></td> <td>1</td> <td></td> <td></td> <td></td> <td></td> <td></td> <td></td> </tr> <tr> <td></td> <td><u>1</u></td> <td> </td> <td></td> <td></td> <td></td> <td></td> <td></td> <td></td> <td></td> </tr> <tr> <td></td> <td></td> <td> </td> <td>3</td> <td>3</td> <td>.</td> <td>3</td> <td>3</td> <td></td> <td>T 1</td> </tr> <tr> <td></td> <td></td> <td> </td> <td></td> <td></td> <td></td> <td></td> <td></td> <td></td> <td></td> </tr> <tr> <td></td> <td>4</td> <td> </td> <td></td> <td></td> <td></td> <td></td> <td></td> <td></td> <td></td> </tr> </table>		1	2	3	4	5	6	7	8	Column	Line	1		1								<u>1</u>												3	3	.	3	3		T 1												4								
	1	2	3	4	5	6	7	8	Column																																																				
Line	1		1																																																										
	<u>1</u>																																																												
			3	3	.	3	3		T 1																																																				
	4																																																												

(begin to edit data)

Procedure 2-9: Press '↑' (Press 'SEL' + '↑, ↓' to change '1' to '2')		1	2	3	4	5	6	7	8	Column
	Line 1			1						
	2	<u>2</u>								
	3			3	3	3	.	3		T 1
	4									

Procedure 2-10: Press 'OK' (save the input data)		1	2	3	4	5	6	7	8	Column
	Line 1			1						
	2	2								
	3			3	3	3	.	3		T 1
	4									

Procedure 2-11: Press '↑' (move the cursor to '1' position)		1	2	3	4	5	6	7	8	Column
	Line 1			1						
	2	2								
	3			3	3	3	.	3		T 1
	4									

Procedure 2-12: Press 'SEL' (begin to edit data)		1	2	3	4	5	6	7	8	Column
	Line 1			<u>1</u>						
	2	2								
	3			3	3	3	.	3		T 1
	4									

2-13: Press '↑' for 3 times (Press 'SEL' and followed by '↑ ↓' to change 1 to 4)		1	2	3	4	5	6	7	8	Column
	Line 1			<u>4</u>						
	2	2								
	3			3	3	3	.	3		T 1
	4	L o								

Procedure 2-14: Press 'OK' (save input data)		1	2	3	4	5	6	7	8	Column
	Line 1			4						
	2	2								
	3			3	3	3	.	3		T 1
	4	L o								

Procedure 2-15: Press '↓' for 3 times (this step leads to editing the action relay)		1	2	3	4	5	6	7	8	Column
	Line 1			4						
	2	2								
	3			3	3	3	.	3		T 1
	4	<u>L o</u>								

② Edit action program and preset the action relay

Procedure 2-16: Press 'SEL' (Begin to modify)		1	2	3	4	5	6	7	8	Column
	Line 1			4						
	2	2								
	3			3	3	3	.	3		T 1
	4	<u>L o</u>								

Procedure 1: Press 'SEL+↑' (Simultaneously)	1	2	3	4	5	6	7	8	Column
	Line 1								
	2	1	[2]	
	3			0	1	0	.	0	T 2
4	I	2							

Last Function Block

	1	2	3	4	5	6	7	8	Column
	Line 1								
	2	2	[4]	
	3			3	3	3	.	3	T 1
4	M	4							

Procedure : Press 'SEL+↓' (Simultaneously)	1	2	3	4	5	6	7	8	Column
	v 1								
	2	2	[3]	
	3			0	5	0	.	0	T F
4	R	1							

Delete Function Block

Procedure : Press 'SEL+DEL' (Simultaneously) ('ESC': Cancel ; 'OK': Execute)	1	2	3	4	5	6	7	8	Column	
	Line 1									
	2	2	[5]		
	3	C	L	E	A	R	B	L	O	C
4	E	S	C	?		O	K	?		

Back to Main Menu:

Press 'ESC'	1	2	3	4	5	6	7	8	Column		
	Line 1										
	2	>	F	U	N	.	B	L	O	C	K
	3		R	U	N						
4		C	L	E	A	R	P	R	O	G	.

Change Function Block Category:

	1	2	3	4	5	6	7	8	Column
	Line 1								
	2	3	[3]	
	3			0	0	0	0		T 2
4	M	4							

Move the cursor to change to T, C, R, G, H, P, L

Step 1: Press 'SEL'	1	2	3	4	5	6	7	8	Column	
	Line 1									
	2	M	1	[2]	
	3			9	9	9	9	9		C 1
4	M	2								

RUN or STOP

(1) RUN Mode

RUN PROG.
➤YES
NO

(2) STOP Mode

STOP PROG.
➤YES
NO

↑ ↓	Move the cursor
OK	Execute the instruction, then back to main menu
ESC	Back to main menu

Other Menu Items

(1) CLEAR PROGRAM (Clear RAM, EEPROM and Password at the same time)

CLEAR PROG.
YES
➤NO

(2) WRITE (save the program (RAM) to the PM05 program spare cartridge)

WRITE
YES
➤NO

(3) READ (read the program from the PM05 program spare cartridge to SG2 (RAM))

READ
YES
➤NO

(1) ~ (3) Now Press:

↑ ↓	Move the cursor
OK	Execute the instruction, then back to main menu
ESC	Back to main menu

(4) SET (system setting)

ID SET	01	→	ID setting (00~99)
REMOTE I / O	N	→	Remote I/O Mode (N: none M: Master S: Slave)
BACK LIGHT	x	→	Back light mode (√: always light x: light for 10s after pressed.)
M KEEP	√	→	M: non-Volatile (√:Volatile x: Non- Volatile)
I/O NUMBER	0	→	Expansion I/O module number (0~3)
I/O ALARM	√	→	Siren setting when is not available to Expansion I/O Points (√:Yes x:No)
C KEEP	x	→	in stop/run switching, Counter Present Value Keeping (√:Yes x:No)
Z SET	x	→	Setting keypad input Z1-Z4 is available (√:Yes x:No)

Note:

M KEEP function is only available for keeping M status in RUN mode when power is re-supplied after loss.

Now Press:

↑↓←→	Move the cursor
SEL	Begin to edit.
Press 'SEL' and '←→'	Move the cursor for 'ID SET item'
Press 'SEL' and '↑↓'	1. ID SET=00~99 ; I/O NUMBER=0~3 2. REMOTE I/O = N↔M↔S↔N 3. BACK LIGHT ; C KEEP ; Z SET =x↔√ 4. M KEEP; I/O ALARM =√↔x
OK	Confirm the Edition Data
ESC	1. Cancel the setting when pressed 'SEL' 2. Back to Main Menu

Note :

When DATALINK is selected, ID setting range is 0~7 , which should be continuous. ID=0 default as Master, ID=1~7 default as Slave

When REMOTE I/O is selected , the distribution of the remote I/O is as follows:

Master			Slave	
Remote Input	X1~X12	←	I1~I12	
Remote Output	Y1~Y8	→	Q1~Q8	

(5) RTC SET

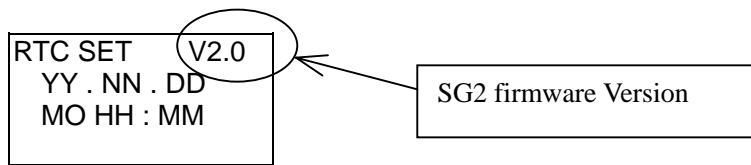

Now Press

SEL	Begin to input parameters
Press 'SEL' + '←→'	Move the Cursor
SEL then ↑ ↓	1. YY=00~99, NN=01~12, DD=01~31 2. MO↔TU↔WE↔TH↔FR↔SA↔SU↔MO 3. HH = 00~23 or MM = 00~59
OK	Save the Input Data
ESC	1. Cancel the Input Data when press 'SEL'. 2. Back to Main Menu.

(6) ANALOG SET

A 1=GAIN : 010	→	GAIN (0~999)
OFFSET : + 00	→	OFFSET (-50~+50)
A 2=GAIN : 010		
OFFSET : + 00		

Now Press

↑↓	1. Move downward the Cursor 2. Switch the setting screen from A1, A2 -> A3, A4 ->A5, A6 -> A7, A8
SEL	Begin to input parameters
Press 'SEL' + '←→'	Move the Cursor
'SEL' + '↑↓'	1. GAIN =000~999 2. OFFSET=-50~+50
OK	Save the Input Data
ESC	1. Cancel the Input Data when press 'SEL'. 2. Back to Main Menu.

Note: V1 = A1*A1_GAIN + A1_OFFSET V8 = A8*A8_GAIN + A8_OFFSET

(7) PASSWORD (setting password)

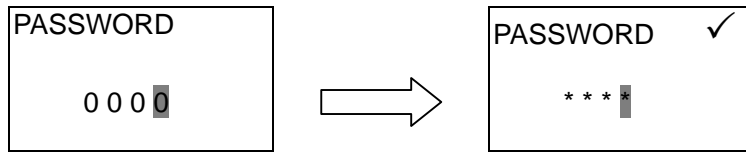

Now Press

SEL	1. Begin to input numeral 2. When the password is ON, it will not display 0000, but ****.
Press 'SEL' + '← →'	Move the cursor
Press 'SEL' + '↑ ↓'	0~F
OK	Save the input data, not 0000 or FFFF, as the PASSWORD is ON.
ESC	1. Cancel the Input Data when press 'SEL'. 2. Back to Main Menu.

Note: If password number is 0001~9FFF, program will be protected.

If password number is A000~FFFE, program and all menu setting will be protected.

(8) LANGUAGE (Selection menu language)

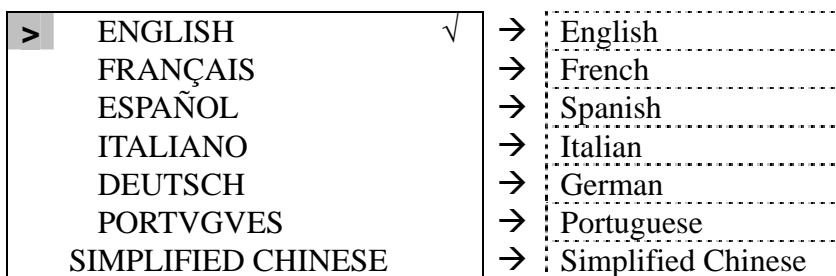

Now Press

Press '↑ ↓'	Vertically move the Cursor
OK	Select the language the cursor located
ESC	Back to Main Menu

Sample:

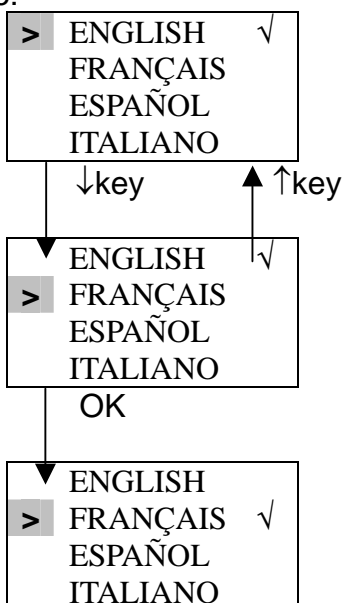

(8) INITIAL (select Ladder Logic and Function Block Diagram (FBD))

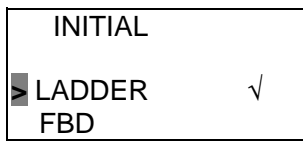

Now Press:



Press '↑↓'	Vertically move the Cursor
OK	Select the language the cursor located
ESC	Back to Main Menu



The origin program will be cleared as the change of edition method.

Chapter 4: Relay Ladder Logic Programming

Common Memory Types

	General output	SET output	RESET output	PULSE output	N.O. Contact	N.C. Contact	Number
Symbol	[▲	▼	P			(N.O. / N.C.)
Input contact					I	i	12 (I1-IC / i1-iC)
Keypad input					Z	z	4(Z1-Z4 / z1-z4)
Output coil	Q	Q	Q	Q	Q	q	8 (Q1-Q8 / q1-q8)
Auxiliary contact	M	M	M	M	M	m	15 (M1-MF / m1-mF)
Counter	C				C	c	15 (C1-CF / c1-cF)
Timer	T			T	T	t	15 (T1-TF / t1-tF)

Inputs (I Memory Type)

The SG2 digital input points are designated I memory types. The number of digital I input points are 6, 8, or 12 depending on each SG2 model.

Keypad Inputs (Z Memory Type)

The SG2 digital input points are designated Z memory types. The number of digital Z input points are 4 depending on SG2 H type model.

Outputs (Q Memory Type)

The SG2 digital output points are designated Q memory types. The number of digital Q output points is 4 or 8 depending on each SG2 model. In this example, output point Q1 will be turned on when input I1 activated.



Auxiliary Relays (M Memory Type)

Auxiliary relays are digital internal memory bits used to control a ladder logic program.

The auxiliary relays are not physical inputs or outputs that can be wired to any external device; switches, sensors, relays, lamps, etc.

Since auxiliary relays are internal bits within the CPU, they can be programmed as digital inputs (contacts) or digital outputs (coils). In the first rung of this example, auxiliary relay M1 is being used as an output coil and will energize when input I2 turns on. In the second rung auxiliary relay M1 is being used as an input and when energized, will turn on outputs Q2 and Q3.



Timers and Timer Status Bits (T Memory Type)

Timer status bits provide the relationship between the current value and the preset value of a selected timer. The timer status bit will be on when the current value is equal or greater than the preset value of a selected timer. In this example, when input I3 turns on, timer T1 will start. When the timer reaches the preset of 5 seconds timer status contact T1 turns on. When T1 turns on, output Q4 turns on. Turning off I3 will reset the timer.



Counters and Counter Status Bits (C Memory Type)

Counter status bits provide the relationship between the current value and the preset value of a selected counter. The counter status bit will be on when the current value is equal to or greater than the preset value of a selected counter. In this example, each time the input contact I4 transitions from off to on, the counter (C1) increments by one. When the counter reaches the preset of 2 counts, the counter status contact C1 turns on. When C1 turns on, output Q5 turns on. When M2 turns on counter C1 will reset. If M9 is turned on, the counter will change from a count-up counter to a count-down counter.

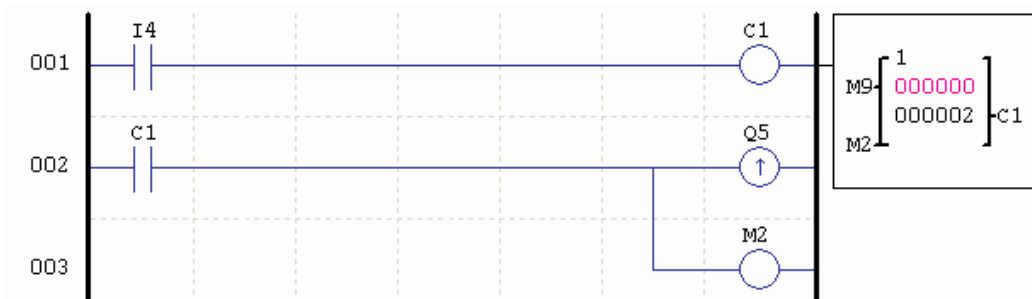

Specialty Memory Types

	General output	SET output	RESET output	PULSE output	N.O. Contact	N.C. Contact	Number
Symbol	[▲	▼	P			(N.O. / N.C.)
					Lo	Hi	Used in function block
Expansion input coil					X	x	12 (X1-XC / x1-xC)
Expansion output coil	Y	Y	Y	Y	Y	y	12 (Y1-YC / y1-yC)
Differential (one shot)					D (Positive)	d (Negative)	
RTC	R				R	r	15 (R1-RF / r1-rF)
Analog comparator	G				G	g	15 (G1-GF / g1-gF)
HMI	H						15 (H1-HF)
PWM	P						1 (P1)
DATA LINK	L						8 (L1-L8)

Positive Input Differential Instruction (One-Shot)

A positive input differential instruction, or One-Shot, holds its status ON for one CPU scan when the preceding series contact transitions from OFF to ON. This transition from OFF to ON is called a Positive Input Differential.

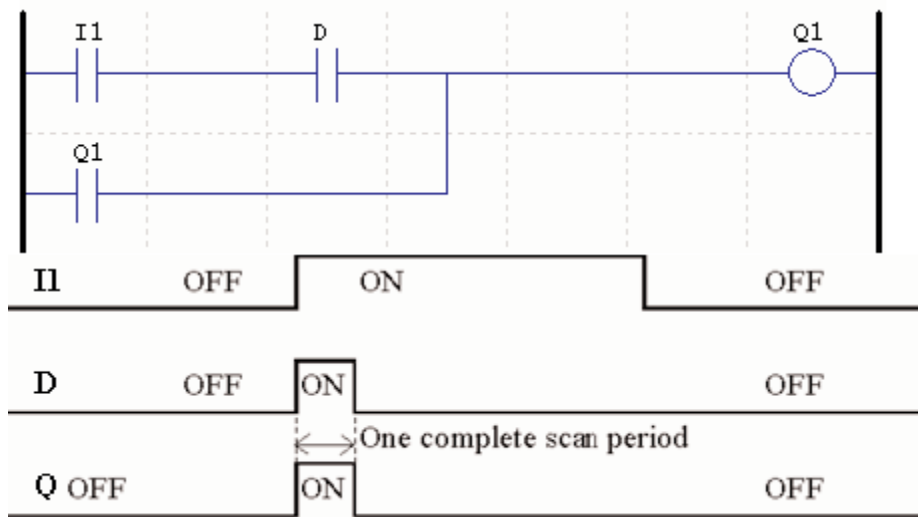

Negative Input Differential Instruction (One-Shot)

A negative input differential instruction, or One-Shot, holds its status ON for one CPU scan when the preceding series contact transitions from ON to OFF. This transition from ON to OFF is called a Negative Input Differential.

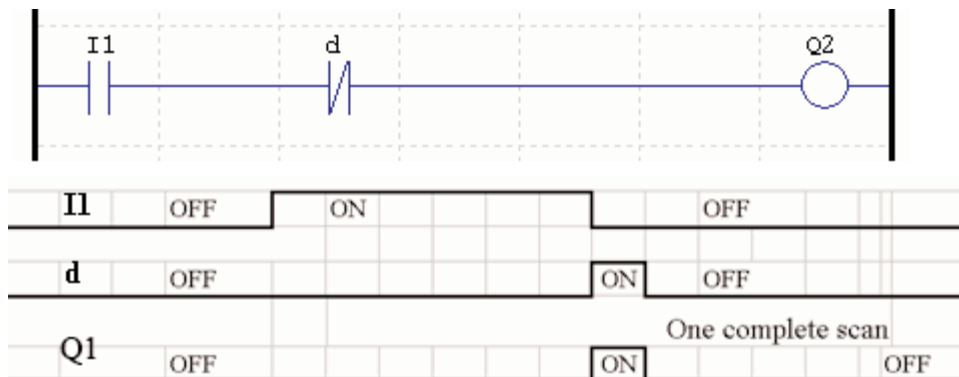

Output Instructions

Set Output Instruction (Latch) ()

A set output instruction, or Latch, turns ON an output coil (Q) or an auxiliary contact (M) when the preceding input contact transitions from OFF to ON. Once the output is ON or set, it will remain ON until it is reset using the Reset output instruction. It is not necessary for the preceding input contact controlling the Set output instruction to remain ON.

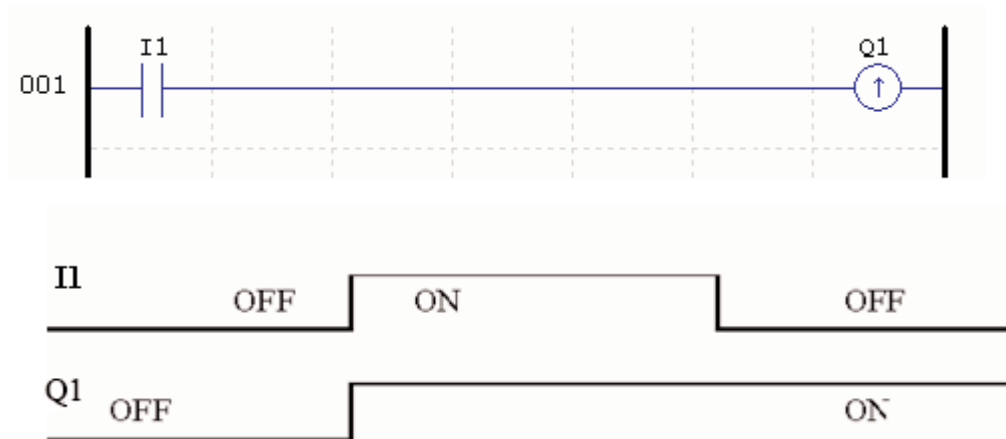

Reset Output Instruction (Unlatch) ()

A reset output instruction, or Unlatch, turns OFF a previous set output coil (Q) or an auxiliary contact (M) when the preceding input contact transitions from OFF to ON. Once the output is OFF or reset, it will remain OFF until it is reset using another output instruction. It is not necessary for the preceding input contact controlling the Reset output instruction to remain ON.

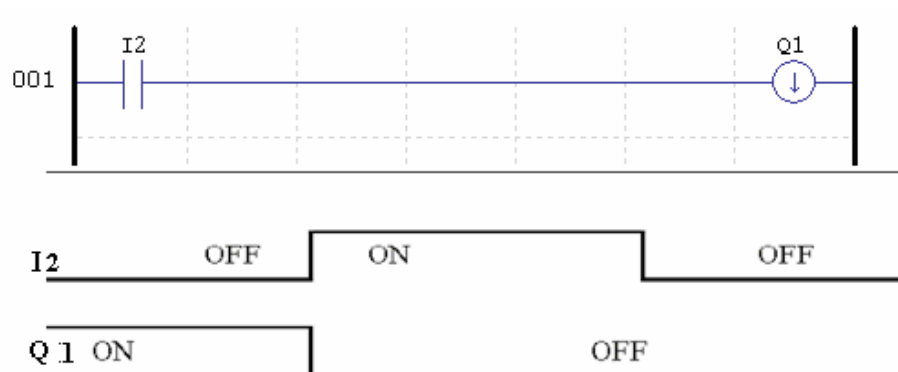

Pulse Output Instruction (Flip-Flop) (P)

A pulse output instruction, or Flip-Flop, turns ON a coil (Q) or an auxiliary contact (M) when the preceding input contact transitions from OFF to ON. Once the output is ON, it will remain ON until the preceding input contact transitions from OFF to ON a second time. In the example below, When Pushbutton I3 is pressed and released Motor Q4 will turn ON and remain on. When Pushbutton I3 is pressed again, Motor Q4 will turn OFF and remain OFF. The pulse output instruction (P) will “flip-flop” its state from ON to OFF at each press of Pushbutton I3.

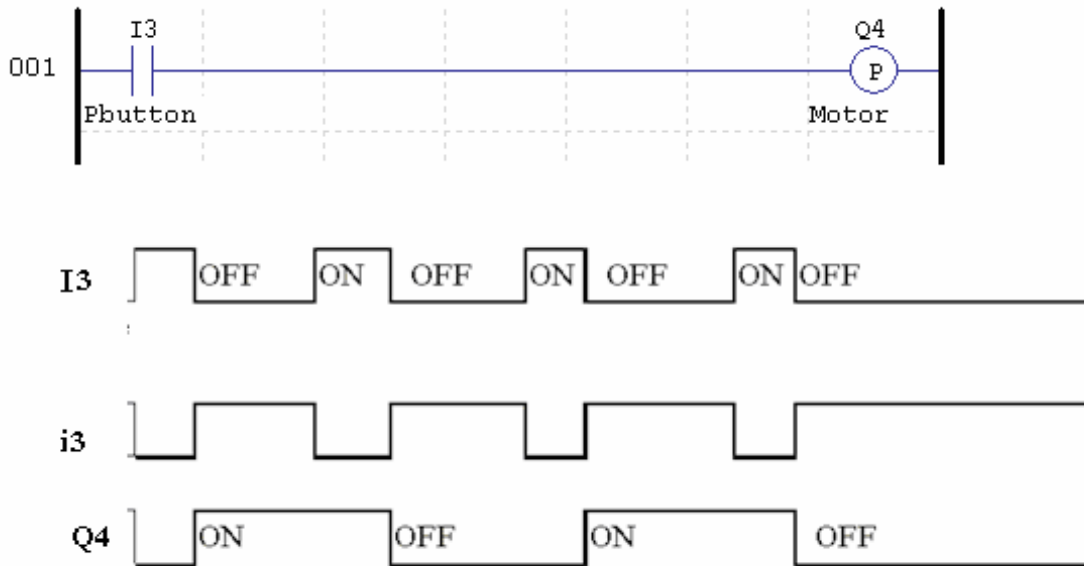

Counter Instructions

The SG2 includes a total 15 separate counters that can be used throughout a program. Each counter has a choice of 8 operation modes, 6 for general purpose counting and 2 for high speed counting. Additionally, each counter has 6 parameters for proper configuration. The tables below describe each configuration parameter and lists each compatible memory type for configuring counters.

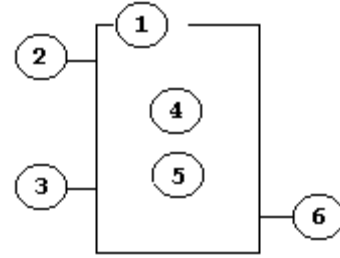

Symbol	Description
①	Counting Mode (1-6)
②	Use (I1 ~ gF) to set counting up or counting down
	OFF: counting up (0, 1, 2, 3, 4...)
	ON: counting down (...3, 2, 1, 0)
③	Use (I1 ~ gF) to RESET the counting value
	ON: the counter resets to zero and OFF
	OFF: the counter continues to count
④	Present Counting Value, range:0~999999
⑤	Target (Setting) Value, range:0~999999
⑥	Code of the counter (C1 ~ CF total: 15 counters)

Compatible Instructions	Range
Inputs	I1-IC / i1-iC
Keypad Inputs	Z1-Z4 / z1-z4
Outputs	Q1-Q8 / q1-q8
Auxiliary coil	M1-MF / m1-mF
Expansion inputs	X1-XC / x1-xC
Expansion outputs	Y1-YC / y1-yC
RTC	R1-RF / r1-rF
Counter	C1-CF / c1-cF
Timer	T1-TF / t1-tF
Analog comparator	G1-GF / g1-gF
Normal close contact	Lo

Note :

The target setting value of the counter could be a constant or the present value of the timer, counter, analog input A1~A8 and analog gain+offset value V1~V8.

The figure below shows the relationship between the numbered block diagram for a Counter, the ladder diagram view, and the software Edit Contact/Coil dialog box.

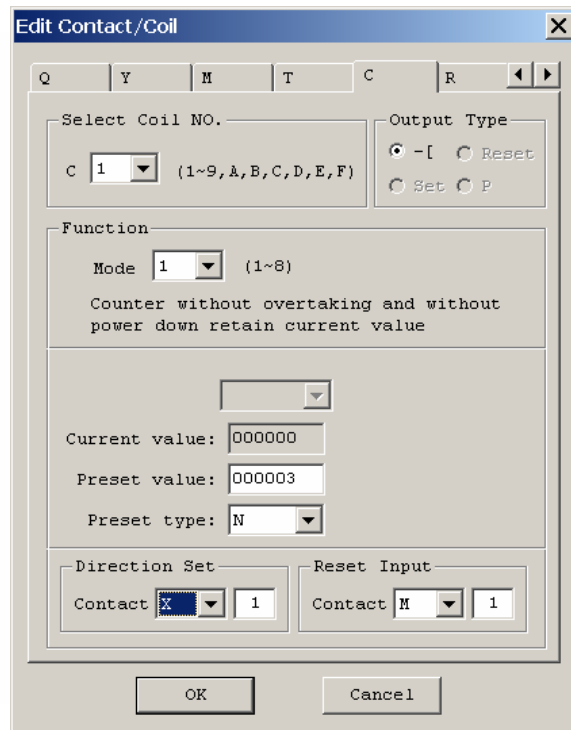
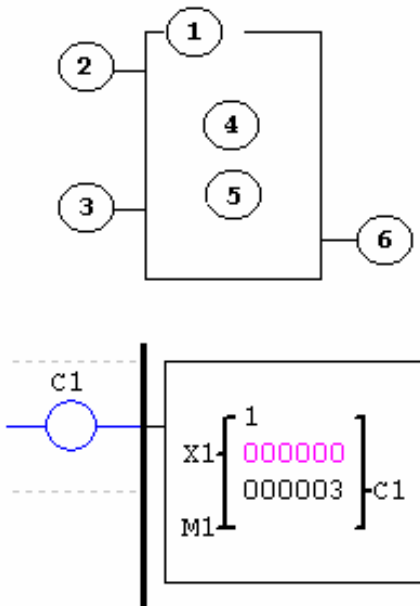

Counter Mode 1 (Fixed Count, Non-Retentive)

Mode 1 Counter will count up to a fixed preset value and stop counting when the current count is equal to the preset value. Additionally, the current count value is non-retentive and will reset to zero on a loss of power to the smart relay. In the example below, the counter will stop counting when it reaches the preset value of 20. Counter status bit C1 will be ON when the current value is 20.

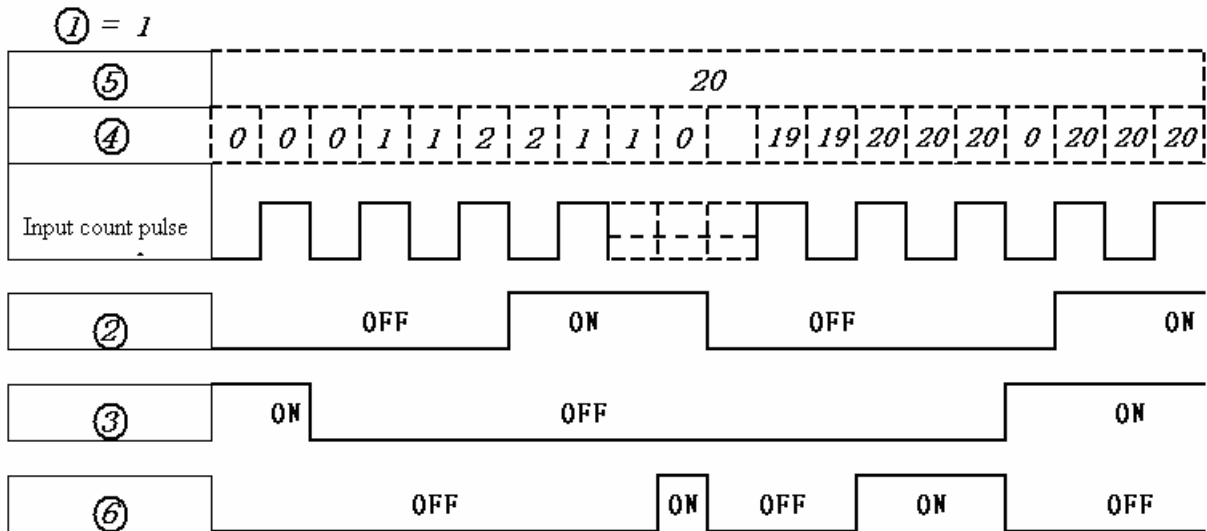
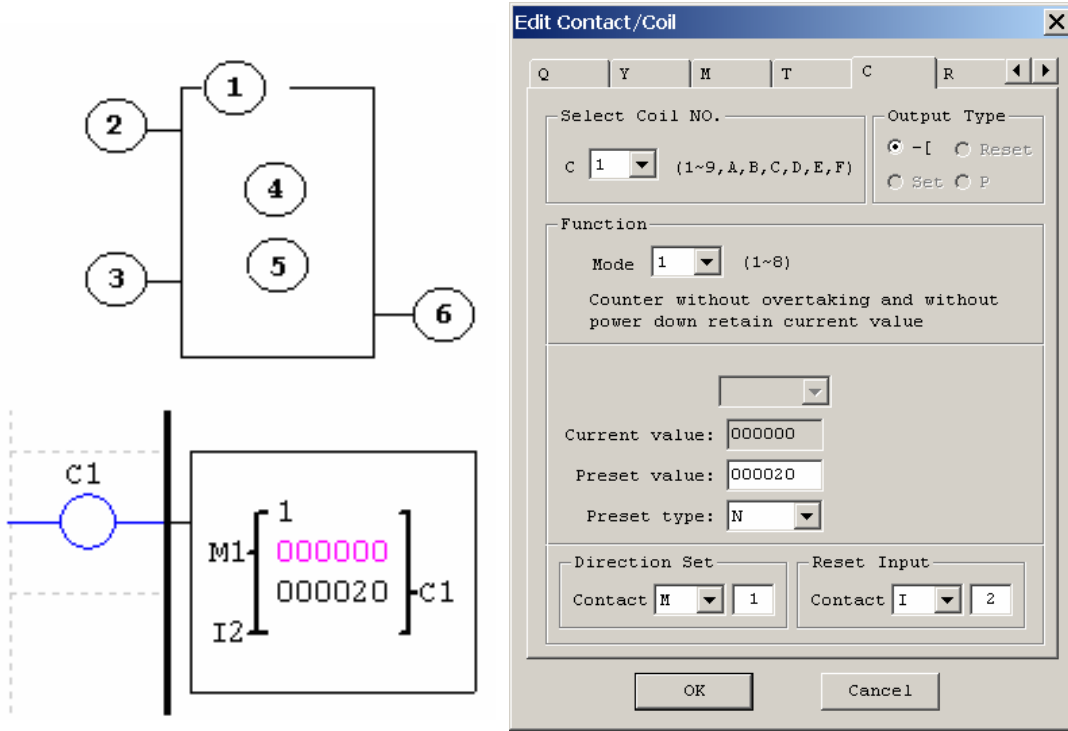

Counter Mode 3 (Fixed Count, Retentive)

Mode 3 Counter operation is similar to Mode 1 except its current count value is retentive. Mode 3 Counter will count up to a fixed preset value and stop counting at that value. Additionally, the current count value is retentive and will keep its current count after a loss of power to the smart relay. In the example below, the counter will stop counting when it reaches the preset value of 20. Counter status bit C1 will be ON when the current value is 20.

The diagram illustrates the physical wiring and the corresponding ladder logic for Counter Mode 3. The physical terminal block has terminals 1, 2, 3, 4, 5, and 6. The ladder logic diagram shows a counter coil C1 with a preset value of 20 and a direction set to M1. The software interface 'Edit Contact/Coil' shows the following settings:

- Select Coil NO.: C 1
- Output Type: -I Reset Set P
- Function: Mode 3 (1~8)
- Counter without overtaking and with power down retain current value
- Current value: 000000
- Preset value: 000020
- Preset type: N
- Direction Set: Contact M 1
- Reset Input: Contact I 2

Counter Mode 4 (Continuous Count, Retentive)

Mode 4 Counter operation is similar to Mode 2 except its current count value is retentive. Mode 4 Counter will count up to a fixed preset value and continue counting after the preset value. Additionally, the current count value is retentive and will keep its current count after a loss of power to the smart relay. In the example below, the counter will continue counting after its preset value of 20. Counter status bit C1 will be ON when the current value is 20.

The diagram illustrates the physical wiring and the corresponding ladder logic for Counter Mode 4. The physical terminal block has terminals 1, 2, 3, 4, 5, and 6. The ladder logic diagram shows a counter coil C1 with a preset value of 20 and a direction set to M1. The software interface 'Edit Contact/Coil' shows the following settings:

- Select Coil NO.: C 1
- Output Type: -I Reset Set P
- Function: Mode 4 (1~8)
- Counter with overtaking and with power down retain current value
- Current value: 000000
- Preset value: 000020
- Preset type: N
- Direction Set: Contact M 1
- Reset Input: Contact I 2

Counter Mode 5 (Continuous Count, Up-Down Counter, Non-Retentive)

Mode 5 Counter operation is similar to Mode 2 where its current count value is continuous and non-retentive, except its C1 status bit will only be ON when the counter counts up to its preset, or down to its preset from a count higher than its preset. Even with its direction bit set to ON, it will not turn on its C1 status bit when it counts down to zero. The C1 status bit is fixed to the non-zero preset value regardless of the state of the direction bit. Additionally, the Mode 5 counter is always reset to zero, unrelated to the state of its direction bit.

The Mode 5 Counter will count up to a fixed preset value and continue counting after the preset value. Additionally, the current count value is non-retentive and will reset to zero on a loss of power to the smart relay. In the example below, the counter will continue counting after its preset value of 20. Counter status bit C1 will be ON when the current value is 20.

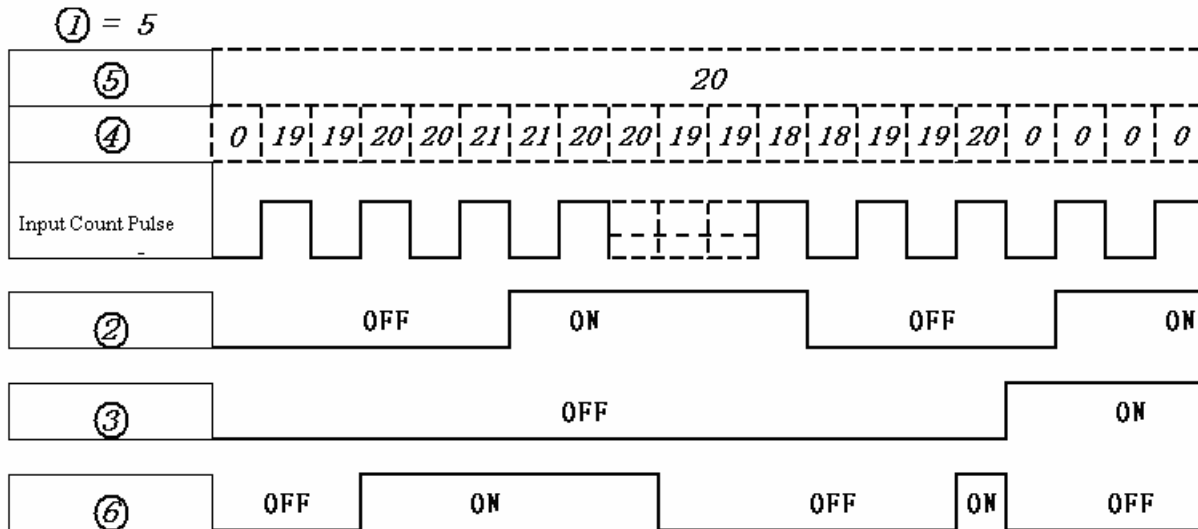
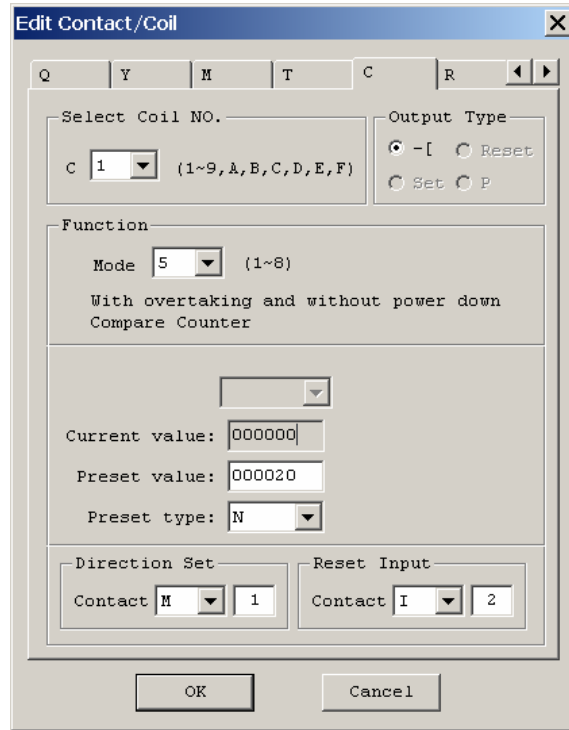
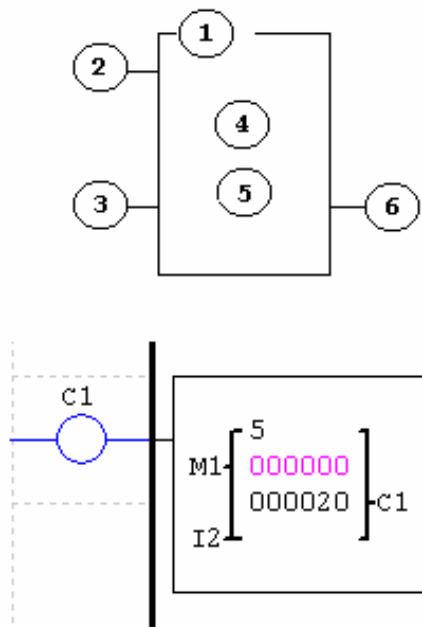

Counter Mode 6 (Continuous Count, Up-Down Counter, Retentive)

Mode 6 Counter operation is similar to Mode 4 where its current count value is continuous and retentive, except its C1 status bit will only be ON when the counter counts up to its preset or down to its preset from a count higher than its preset. Even with its direction bit set to ON, it will not turn on its C1 status bit when it counts down to zero. The C1 status bit is fixed to the non-zero preset value regardless of the state of the direction bit. Additionally, the Mode 5 counter is always reset to zero, unrelated to the state of its direction bit.

The Mode 6 Counter will count up to a fixed preset value and continue counting after the preset value. Additionally, the current count value is retentive and will keep its current count after a loss of power to the smart relay. In the example below, the counter will continue counting after its preset value of 20. Counter status bit C1 will be ON when the current value is 20.

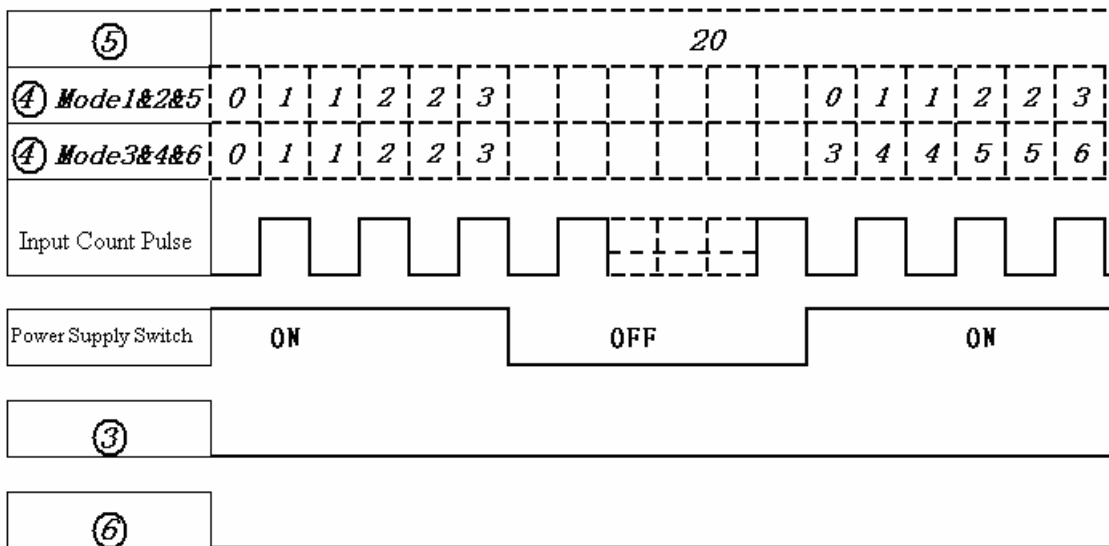
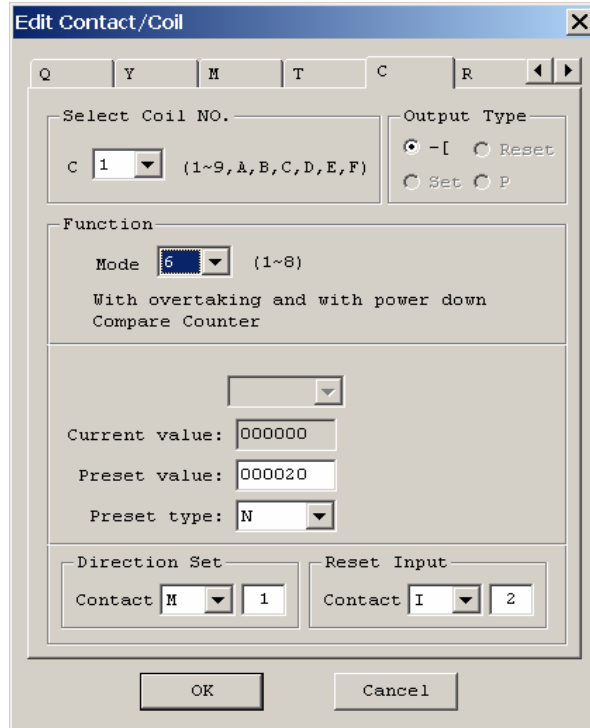
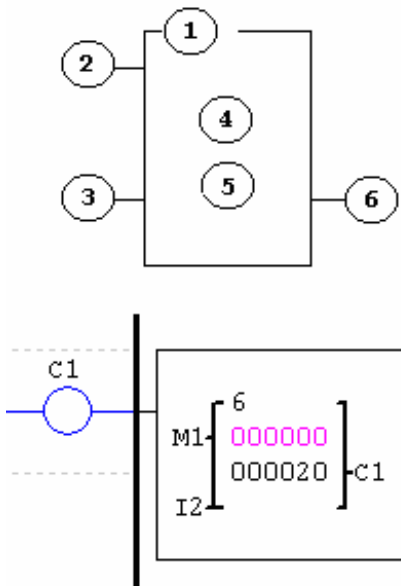

High Speed Counters (DC Version Only)

The DC powered version smart relays include two 1 KHz high speed inputs on terminal I1 and I2. These can be used as general purpose DC inputs or can be wired to a high speed input device (encoder, etc.) when configured for high speed counting. These are often used for counting something moving very fast (>40Hz) or used as a speed reference on a machine. The high speed counters are configured using the same software Edit Contact/Coil dialog box, except selecting Counter Mode 7 or Mode 8.

High Speed Counter Mode 7 (DC powered versions only)

The Mode 7 High Speed Counter can use either input terminals I1 or I2 for forward up-counting to 1KHz maximum at 24VDC high speed input signal. The selected Counter Coil (C1-CF) will turn ON when the pulse count reaches the target setpoint and remain ON. The counter will reset when the preceding rung is inactive or the Reset Input is active.

Symbol	Description
①	Counting Mode (7) high speed counting
②	High speed counting input terminal: I1 or I2 only
③	Use (I1 ~ gF) to RESET the counting value ON: the counter reset to zero OFF: the counter continues to count
④	Current Count Value, range:0~999999
⑤	Preset Value, range:0~999999
⑥	Counter Coil Number (C1 ~ CF total: 15 counters)

In the example below shows the relationship between the numbered block diagram for a Mode 7 Counter, the ladder diagram view, and the software Edit Contact/Coil dialog box.

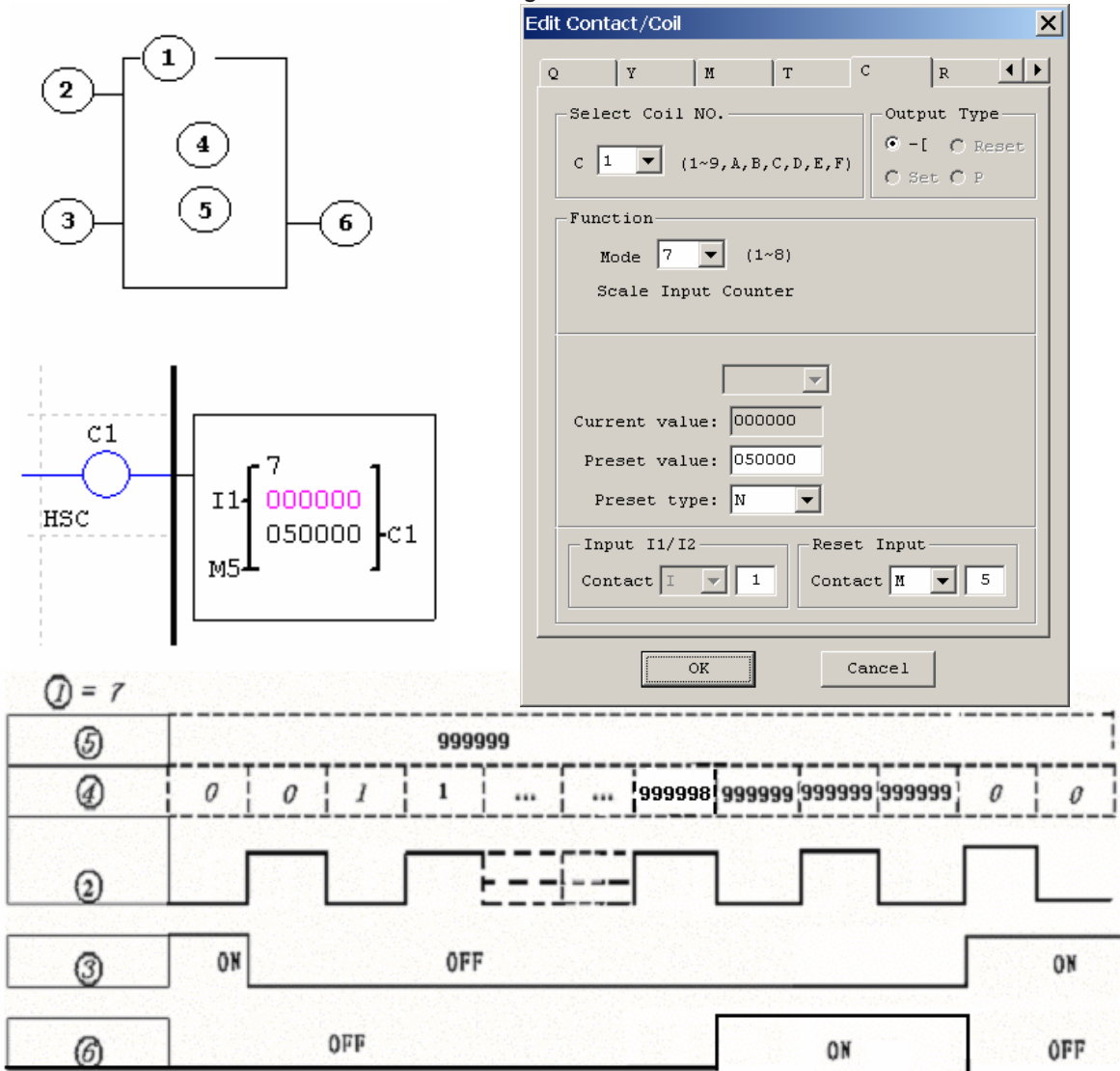

High Speed Counter Mode 8 (DC powered versions only)

The Mode 8 High Speed Counter can use either input terminals I1 or I2 for forward up-counting to 1 KHz maximum at 24VDC high speed input signal. The selected Counter Coil (C1-CF) will turn ON when the pulse count reaches the target “Preset ON” value and remain ON until the pulse count reaches the target “Preset OFF” value. The Fixed Time xxxx. The counter will reset when the preceding rung is inactive. The table below describes each configuration parameter for High Speed Counter Mode 8.

Symbol	Description
①	Counting Mode(8)—Frequency Comparison
②	High speed counting input terminal: only I1, I2
③	Counting interval time:(0~99.99S)
④	Counter 'on' target value (000000~999999)
⑤	Counter 'off' target value (000000~999999)
⑥	Code of Counter (C1~CF Total :15Group)

In the example below shows the relationship between the numbered block diagram for a Mode 8 Counter, the ladder diagram view, and the software Edit Contact/Coil dialog box.

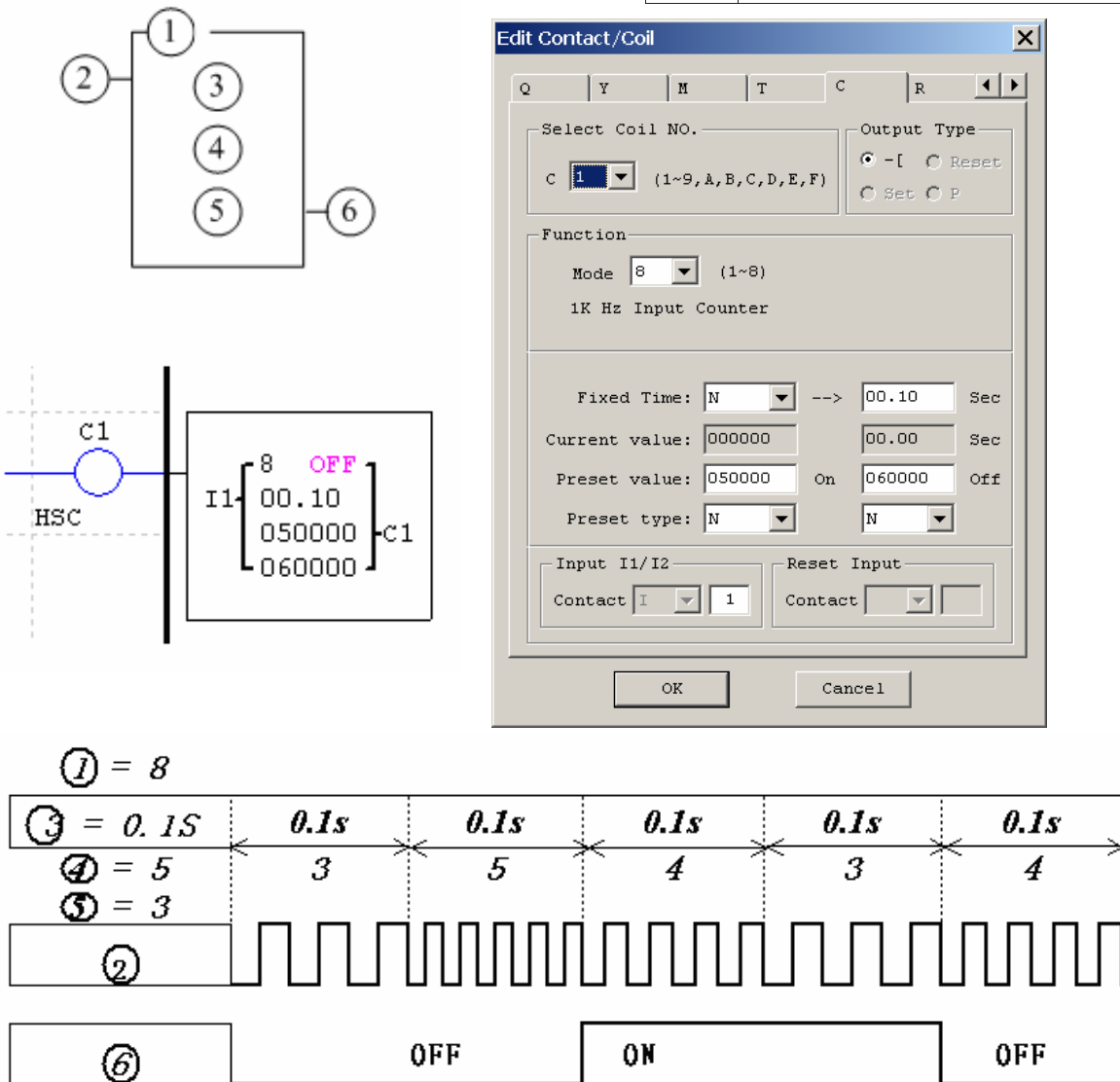

Timer Instructions

The SG2 includes a total of 15 separate timers that can be used throughout a program. Each timer has a choice of 8 operation modes, 7 for general purpose timing and 1 (mode 7) for a pulse timer. Additionally, each timer has 6 parameters for proper configuration. The table below describes each configuration parameter and lists each compatible memory type for configuring counters.

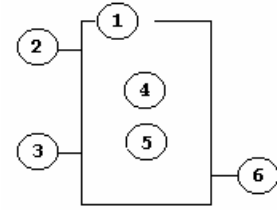

Symbol	Description
①	Timer Mode (0-7)
②	Timer Unit: 1 : 0.00 - 99.99 sec
	2 : 0.0 - 999.9 sec
	3 : 0 - 9999 sec
	4 : 0 - 9999 min
③	ON: the timer reset to zero
	OFF: the timer continues to time
④	Current timer value
⑤	Timer preset value
⑥	Timer Coil Number (C1 ~ CF total: 15 timers)

Compatible Instructions	Range
Inputs	I1-IC / i1-iC
Keypad Inputs	Z1-Z4 / z1-z4
Outputs	Q1-Q8 / q1-q8
Auxiliary coil	M1-MF / m1-mF
Expansion inputs	X1-XC / x1-xC
Expansion outputs	Y1-YC / y1-yC
RTC	R1-RF / r1-rF
Counter	C1-CF / c1-cF
Timer	T1-TF / t1-tF
Analog comparator	G1-GF / g1-gF
Normal close contact	Lo

Note :

The target setting value of the counter could be a constant or the present value of the timer, counter, analog input A1~A8 and analog gain+offset value V1~V8.

Timer Mode 0 (Internal Coil)

Mode 0 Timer (Internal Coil) used as internal auxiliary coils. No Timer preset value. In the example below shows the relationship between the numbered block diagram for a Mode 0 timer, the ladder diagram view, and the software Edit Contact/Coil dialog box.

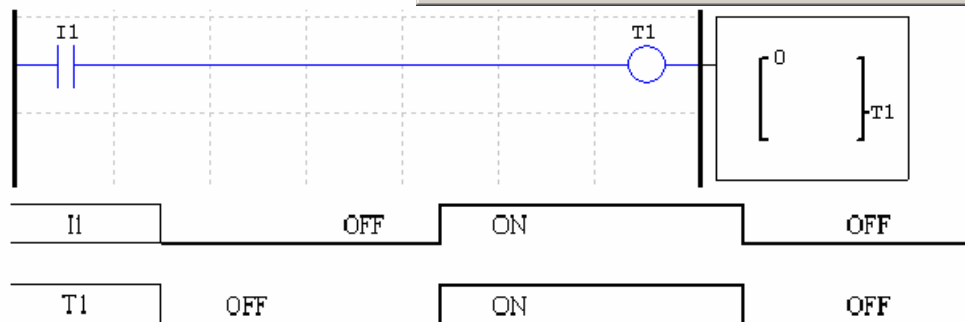
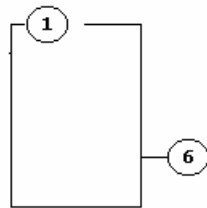
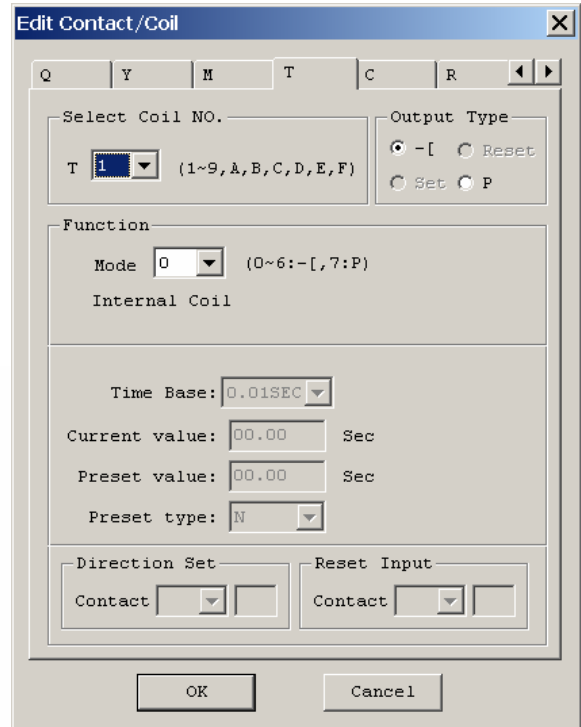

Timer Mode 1 (ON-Delay)

Mode 1 Timer (ON-Delay) will time up to a fixed preset value and stop timing when the current time is equal to the preset value. Additionally, the current time value is non-retentive and will reset to zero on a loss of power to the smart relay. In the example below, the timer will stop timing when it reaches the preset value of 5 seconds. Timer status bit T1 will be ON when the current value is 5.

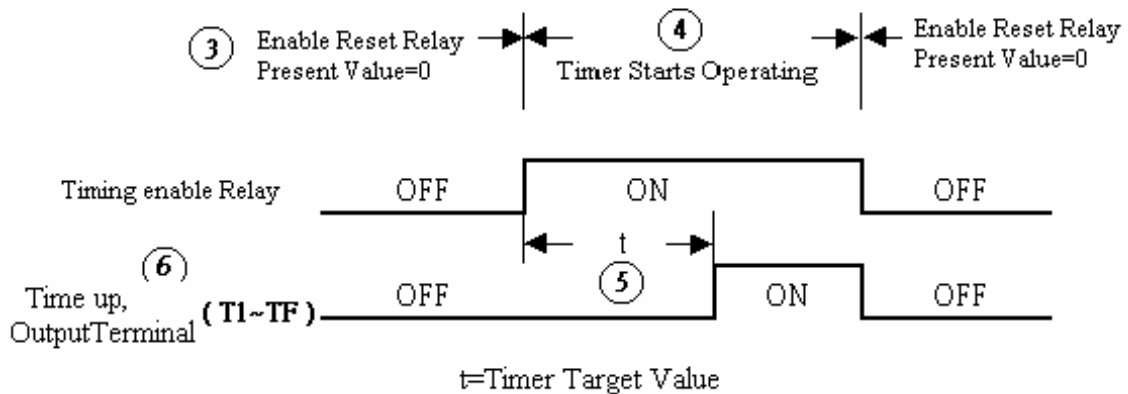
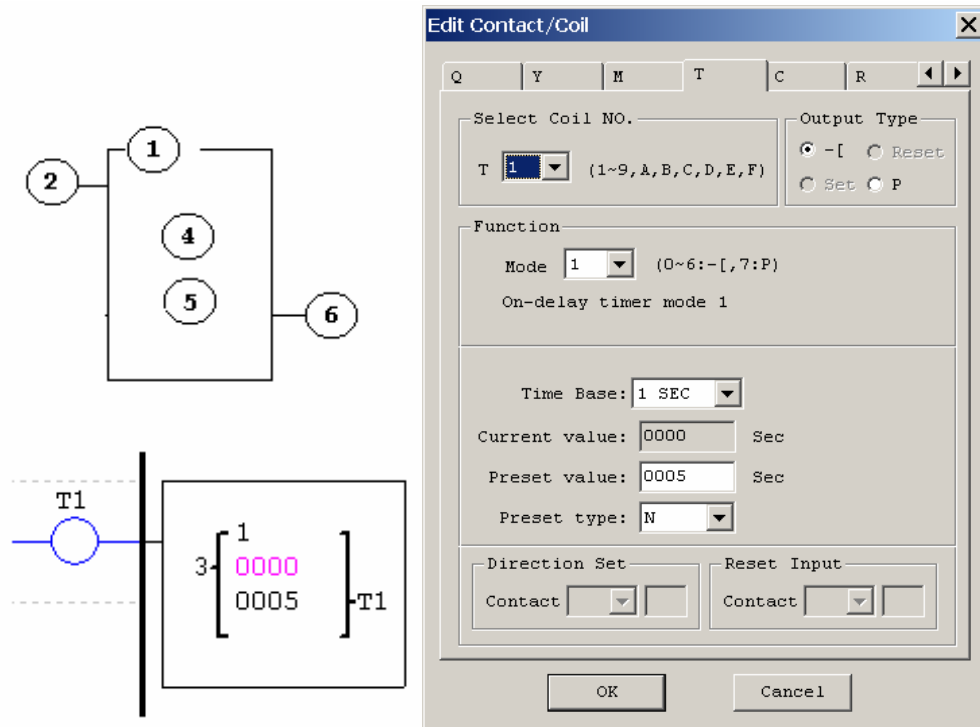

Timer Mode 2 (ON-Delay with Reset)

Mode 2 Timer is an ON-Delay with reset that will time up to a fixed preset value and stop timing when the current time is equal to the preset value. Additionally, the current time value is non-retentive and will reset to zero on a loss of power to the smart relay. The timer reset input is Input I1. In the example below, the timer will stop timing when it reaches the preset value of 5 seconds. Timer status bit T1 will be ON when the current value is 5.

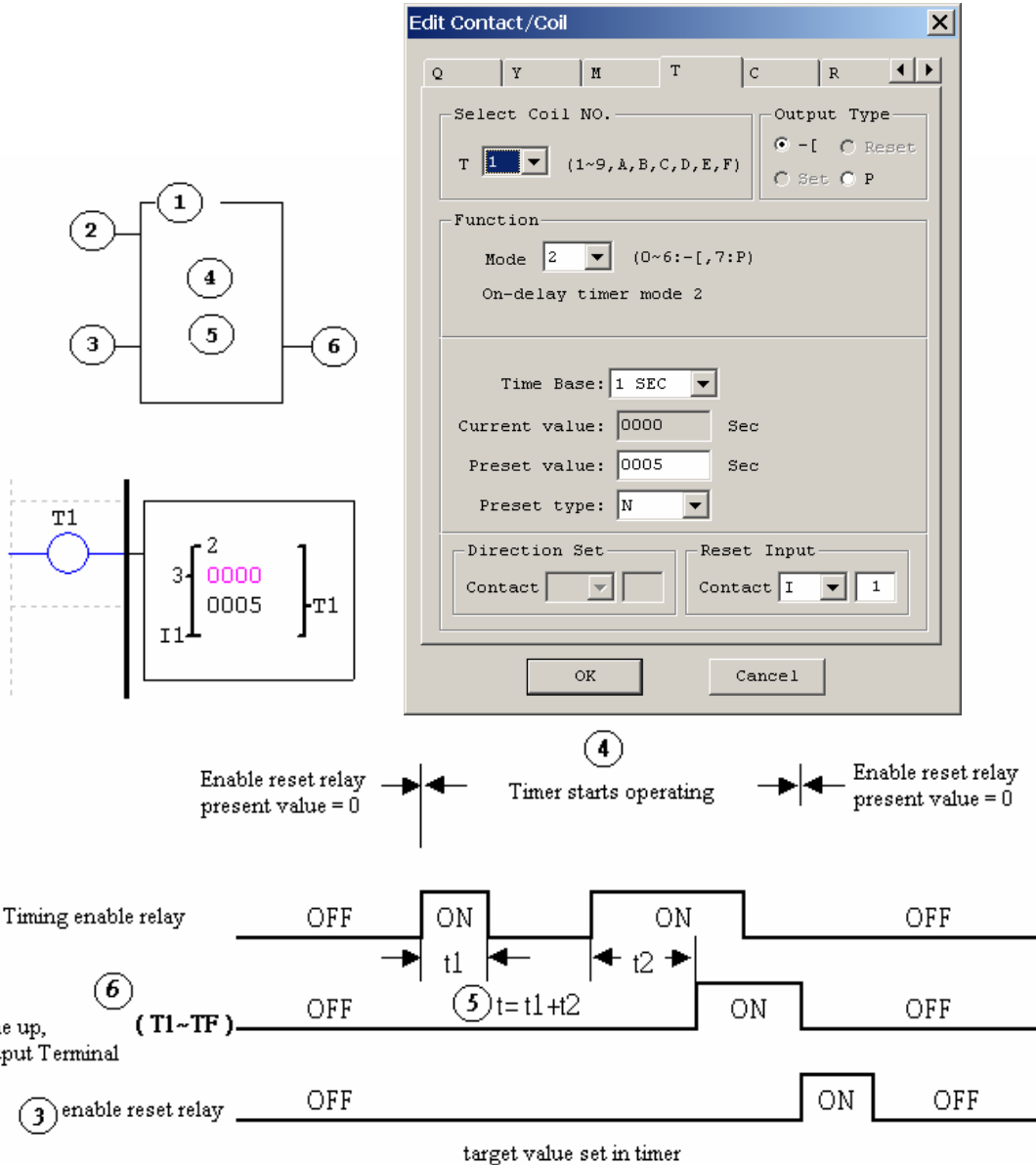

Timer Mode 3 (OFF-Delay)

Mode 3 Timer is an OFF-Delay with reset that will time up to a fixed preset value and stop timing when the current time is equal to the preset value. Additionally, the current time value is non-retentive and will reset to zero on a loss of power to the smart relay. In the example below, the timer reset input is Input I1. Also in the example below, timer status bit T1 will be ON immediately when its rung is true. The timer will only begin timing up when its rung changes to false. Timer status bit T1 will turn OFF when the current time value reaches 10 seconds.

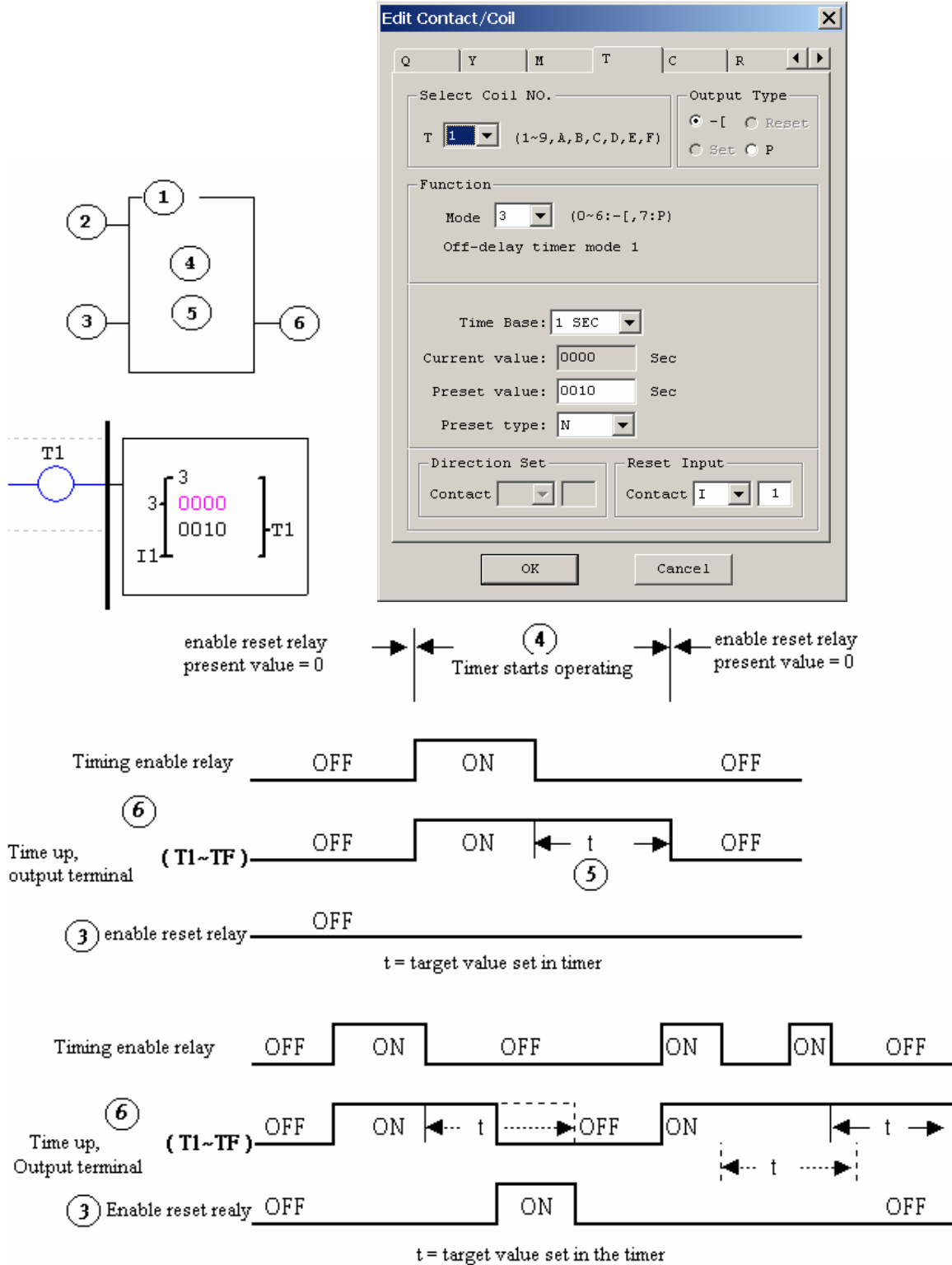

Timer Mode 4 (OFF-Delay)

Mode 4 Timer is an OFF-Delay with reset that will time up to a fixed preset value and stop timing when the current time is equal to the preset value. Additionally, the current time value is non-retentive and will reset to zero on a loss of power to the smart relay. In the example below, the timer reset input is Input I1. Also in the example below, the timer status bit T1 will turn ON only after its rung transitions from true to false. Timer status bit T1 will turn OFF when the current time value reaches 10 seconds.

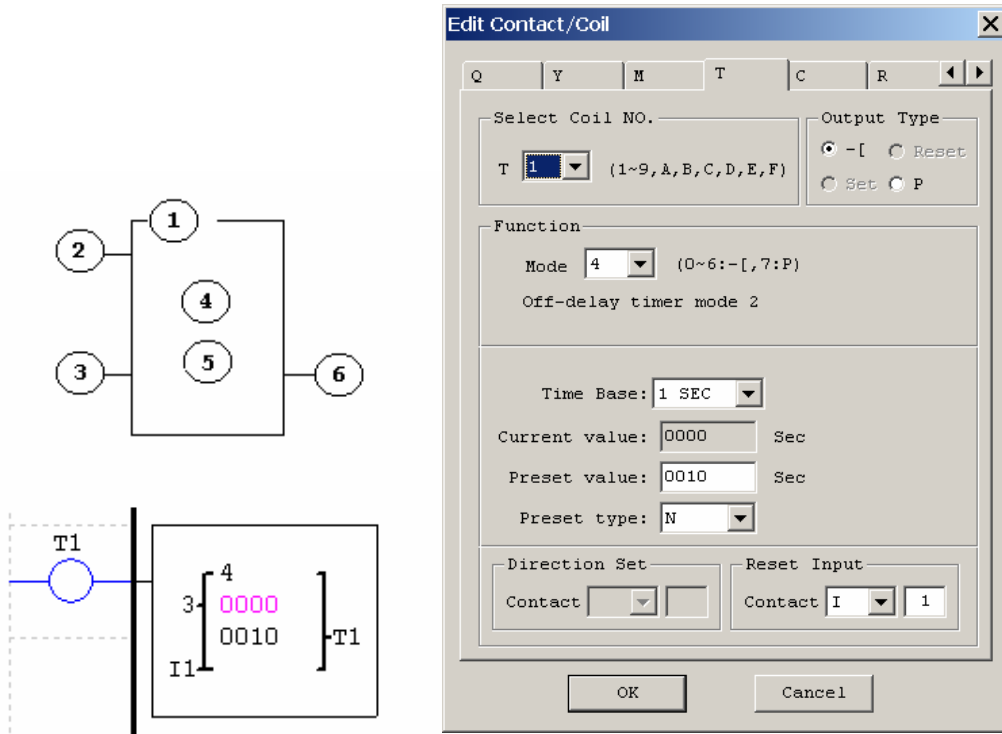

enable reset relay present value = 0 ← Timer starts operating → Enable reset relay present value = 0

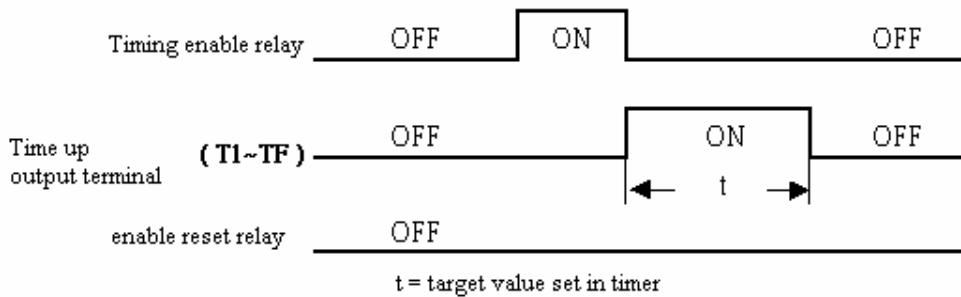

Timer Mode 5 (FLASH without Reset)

Mode 5 Timer is a Flash timer without reset that will time up to a fixed preset value then change the state of its status bit when the current time is equal to the preset value. Additionally, the current time value is non-retentive and will reset to zero on a loss of power to the smart relay. In the example below, timer status bit T1 will be ON immediately when its rung is true and begin its timing sequence. Timer status bit T1 will turn OFF when the current time value reaches its preset of 10 seconds. This Flash sequence of the timer status bit T1 will continue as long as its rung remains true.

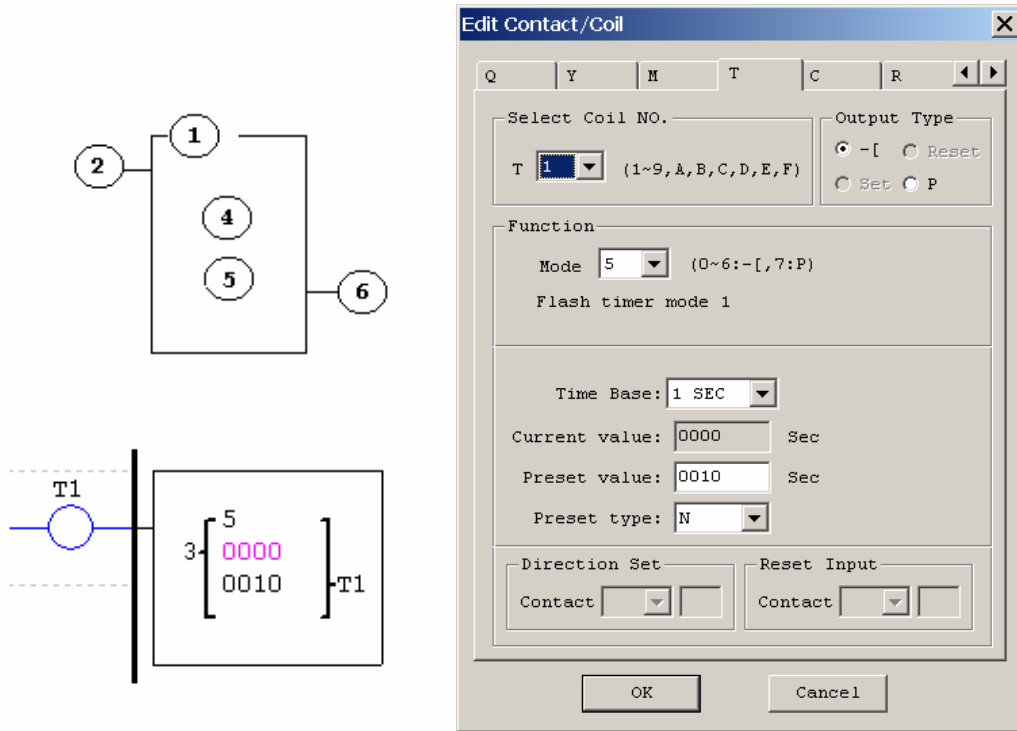

Enable reset rely present value = 0 →|← Timer starts operating →|← Enable reset rely Present value = 0

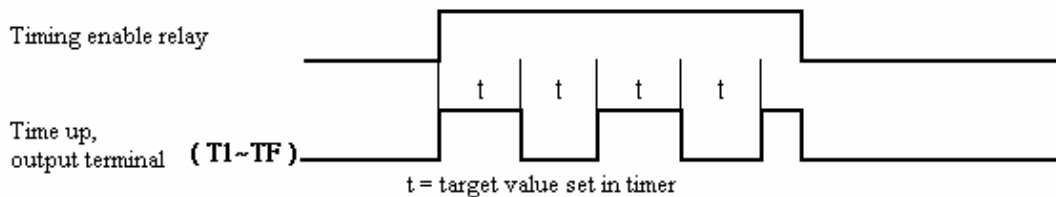

Timer Mode 6 (FLASH with Reset)

Mode 6 Timer is a Flash timer with reset that will time up to a fixed preset value then change the state of its status bit when the current time is equal to the preset value. Additionally, the current time value is non-retentive and will reset to zero on a loss of power to the smart relay. In the example below, the timer reset input is Input I1. Also in the example below, timer status bit T1 will be ON immediately when its rung is true and begin its timing sequence. Timer status bit T1 will turn OFF when the current time value reaches its preset of 5 seconds. This Flash sequence of the timer status bit T1 will continue as long as its rung remains true.

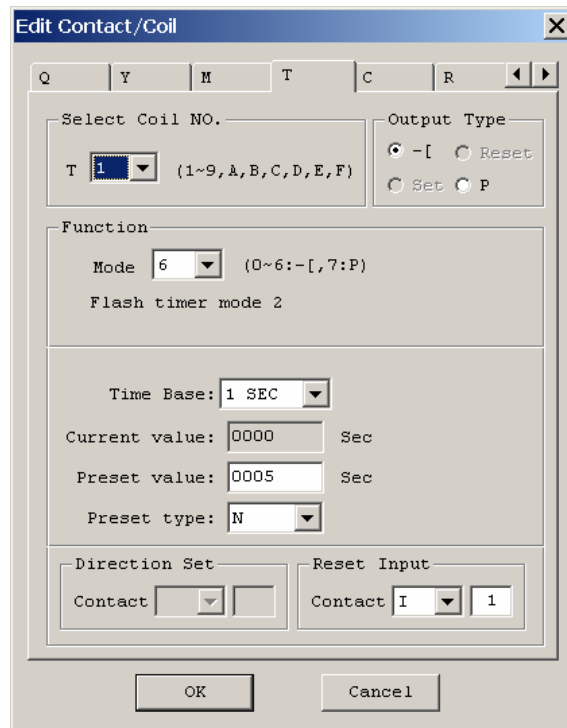
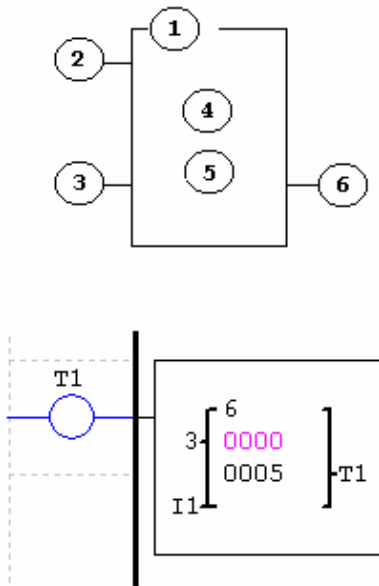

enable reset relay present value = 0 → ← Timer starts operating → ← enable reset relay present value = 0

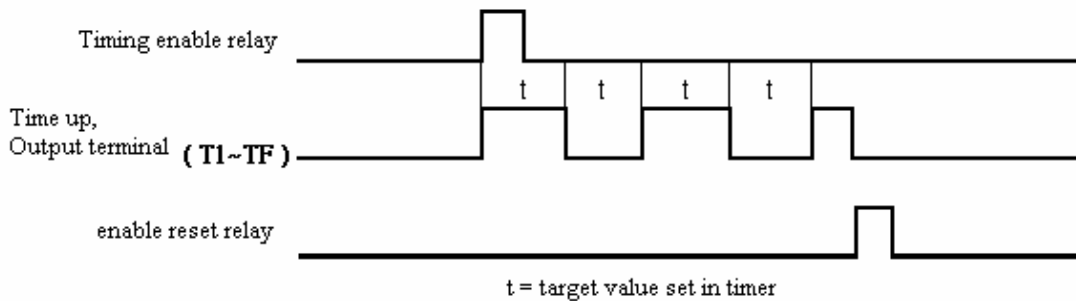

Timer Mode 7 (FLASH Cascade without Reset)

Mode 7 Timer is a Flash timer without reset that uses two timers in a cascade configuration. The cascade configuration connects the timer status bit of first timer to enable the second timer. The second timer will time up to its preset value then flash and its timer status bit will enable the first timer. Additionally, the current time value is non-retentive and will reset to zero on a loss of power to the smart relay. In the example below, timer status bit T1 will be ON after it completes its timing sequence of 2.5 seconds. Timer 2 will then begin its timing sequence of 1 second. When the current time value of Timer 2 reaches its preset of 1 second, its status bit T2 will flash and Timer 1 will begin timing again. This type of cascade timer is often used in combination with a counter in applications where it is necessary to count the number of time cycles completed.



Note: Timer Mode 7 uses two timers. These timers cannot be reused as timers for other modes in other areas of the program.

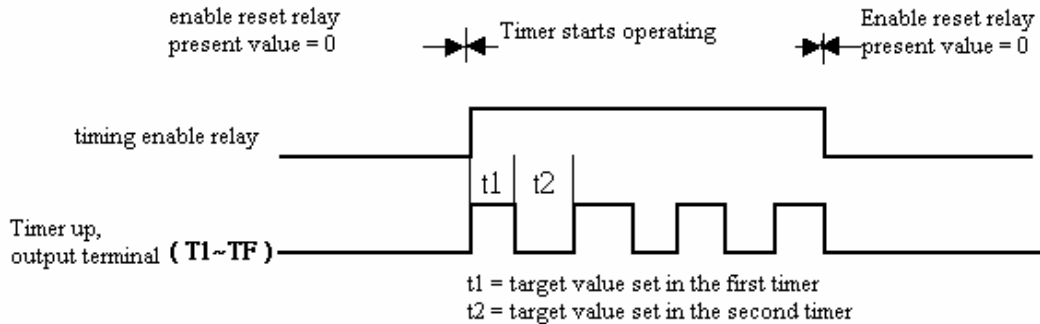
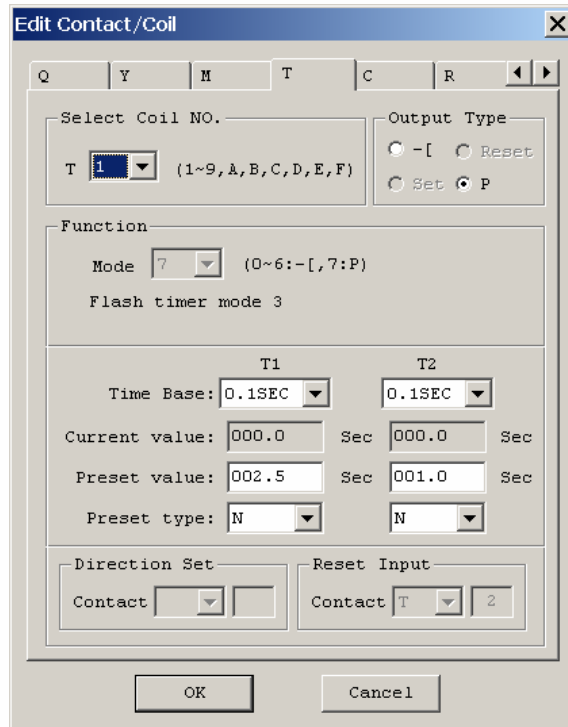
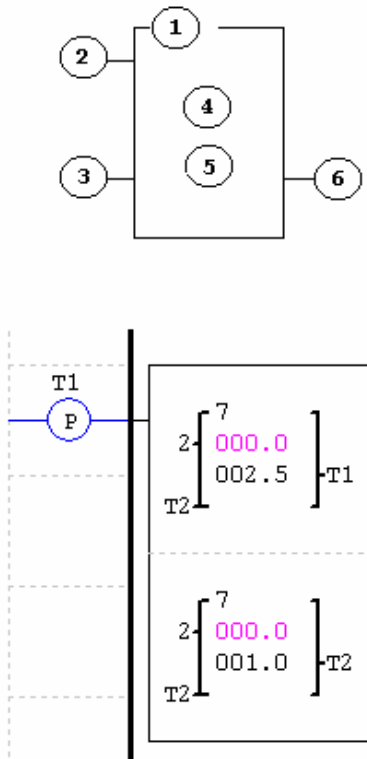

Real Time Clock (RTC) Instructions

The SG2 smart relay includes a total of 15 separate RTC instructions that can be used throughout a program. Each RTC instruction has a choice of 5 operation modes, and has 10 parameters for proper configuration. The initial clock/calendar setting for each connected SG2 is set using the **Operation»RTC Set** menu selection from the SG2 Client software.

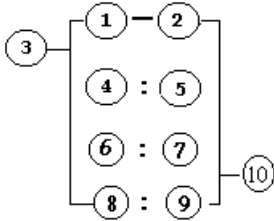
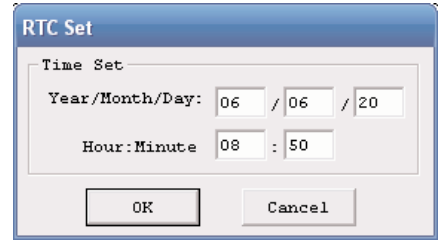

Symbol	Description
①	Input the first week to RTC
②	Input the second week to RTC
③	RTC mode 0~2, 0: internal coil 1:daily, 2:consecutive days
④	RTC displays the hour of present time.
⑤	RTC displays the minute of present time
⑥	Set RTC hour ON
⑦	Set RTC Minute ON
⑧	Set RTC Hour OFF
⑨	Set RTC Minute OFF
	RTC Coil Number (R1~RF Total: 15 RTCs)

RTC Mode 0 (Internal Coil)

Mode 0 RTC (Internal Coil) used as internal auxiliary coils. No preset value. In the example below shows the relationship between the numbered block diagram for a Mode 0 RTC, the ladder diagram view, and the software Edit Contact/Coil dialog box.

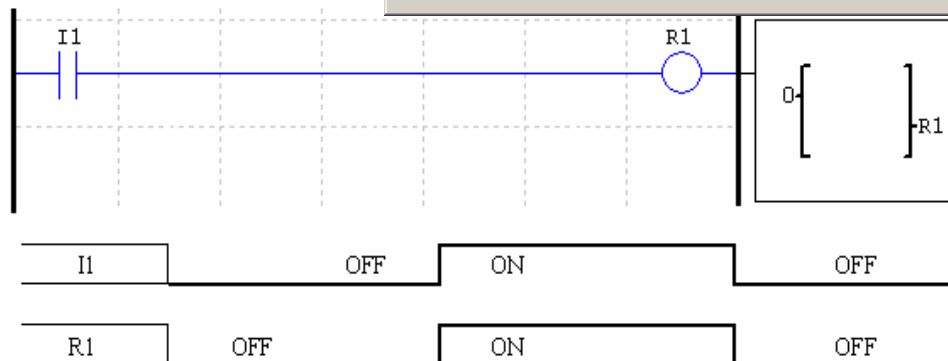
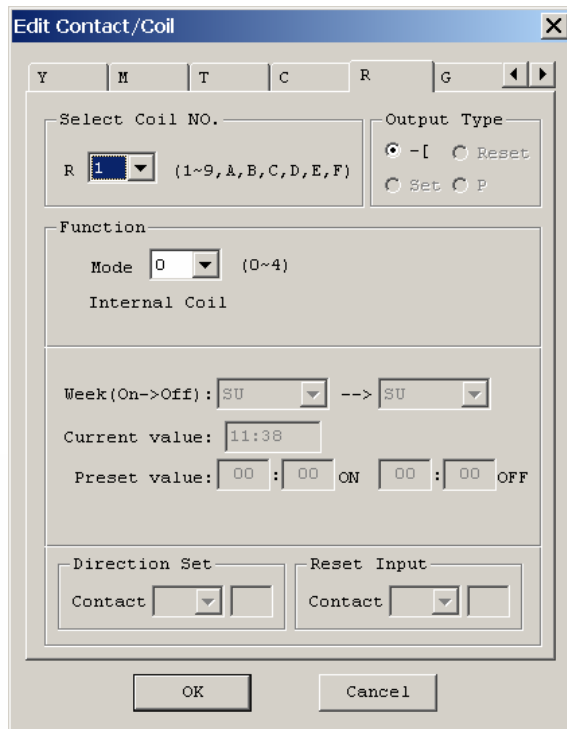
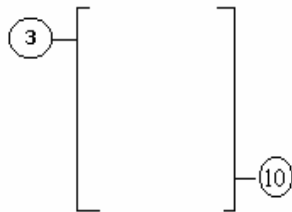

RTC Mode 1 (Daily)

The Daily Mode 1 allows the Rx coil to activate based on a fixed time across a defined set of days per week. The configuration dialog below allows for selection of the number of days per week (i.e. Mon-Fri) and the Day and Time for the Rx coil to activate ON, and Day and Time for the Rx coil to deactivate OFF.

Terminal block with connections 1-10. Coil R1 is connected to terminals 1 and 2. Configuration box shows: TU-FR, 11:41, 08:00, 17:00, R1.

Edit Contact/Coil

Y M T C R G

Select Coil NO.: R (1~9, A, B, C, D, E, F)

Output Type: - [Reset Set P

Function: Mode 1 (0~4)
Every day action mode

Week (On->Off): TU --> FR

Current value: 11:43

Preset value: 08 : 00 ON 17 : 00 OFF

Direction Set: Contact [] []

Reset Input: Contact [] []

OK Cancel

Week	Monday	Tuesday	Wednesday	...	Friday	Saturday	Sunday
Time	8:00 17:00	8:00 17:00	8:00 17:00		8:00 17:00		
ENABLE	[Active]						
Rn Output	[Inactive]	[Active]	[Active]	[Inactive]	[Active]	[Inactive]	[Inactive]

RTC Mode 3 (Year-Month-Day)

The Year-Month-Day Mode 3 allows the Rx coil to activate based on Year, Month, and Date. The configuration dialog below allows for selection of Year and Date for the Rx coil to activate ON, and Year and Date for the Rx coil to deactivate OFF.

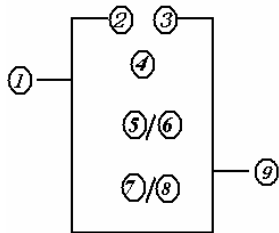

Symbol	Description
①	RTC mode 3, Year-Month-Day
②	Setting RTC Year ON
③	Setting RTC Year OFF
④	Display RTC Present time: Year-Month-Day
⑤	Setting RTC month ON
⑥	Setting RTC Day ON
⑦	Setting RTC month OFF
⑧	Setting RTC Day OFF
⑨	RTC Code (R1~RF, total 15 group)

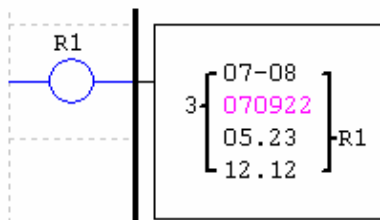
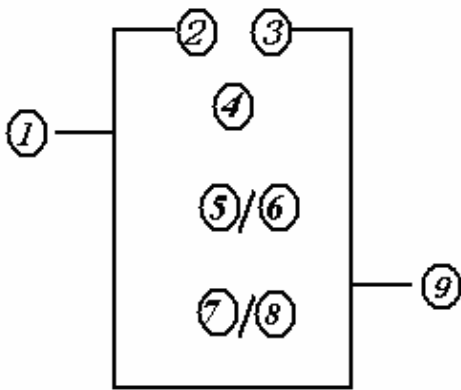

Edit Contact/Coil

Y M T C R G

Select Coil NO. R (1~9, A, B, C, D, E, F)

Output Type
 -I Reset
 Set P

Function
 Mode 3 (0~4)
 Interval Month action mode

Year (On->Off): 07 --> 08

Current value: 07.09.22

Preset value: 05 . 23 ON 12 . 12 OFF

Direction Set
 Contact ▼

Reset Input
 Contact ▼

OK Cancel

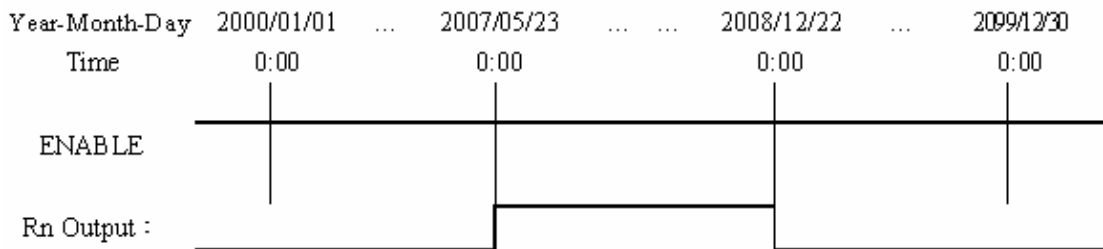

RTC Mode 4 (30-second adjustment)

The 30-second adjustment Mode 4 allows the Rx coil to activate based on week, hour, minute and second. The configuration dialog below allows for selection of week, hour, minute and second for the Rx coil to activate ON, and 30-second adjustment then Rx OFF.

Symbol	Description
①	Setting RTC adjustment week
②	RTC mode 4
③	RTC present hour
④	RTC present minute
⑤	Setting RTC adjustment hour
⑥	Setting RTC adjustment minute
⑦	Setting RTC adjustment second
⑧	RTC Code (R1~RF, total 15 group)

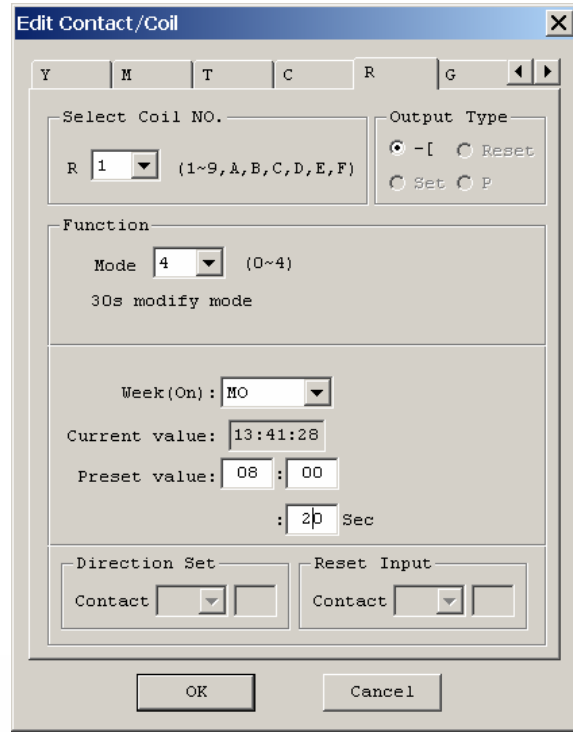

Example1: preset minute < 30s

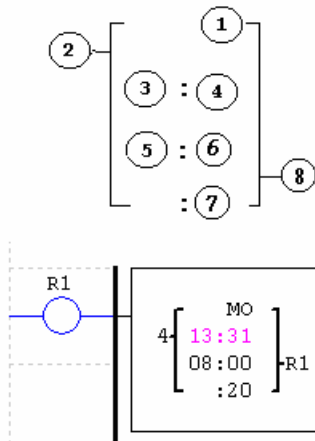

Week	Sunday	Monday	Tuesday	..	Friday	Saturday
Time	8:00 17:00	8:00 17:00	8:00 17:00		8:00 17:00	

ENABLE _____

Rn Output: _____

** Note : If ENABLE fails, output is OFF.

While present time is 8:00 20second on Monday and Rn output is OFF, Rn will be adjustment, present time will be adjustment to 8:00 0second, and Rn output is ON. When time increased 8:00 21second, Rn output is OFF (Rn output is on 21second).

Example2: preset minute >= 30s

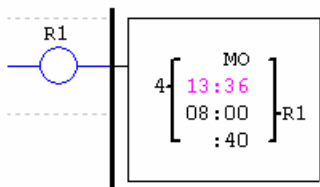

Week	Sunday	Monday	Tuesday	...	Friday	Saturday
Time	8:00 17:00	8:00 17:00	8:00 17:00		8:00 17:00	

ENABLE _____

Rn Output: _____

** Note : If ENABLE fails, output is OFF.

While present time is 8:00 40second on Monday and Rn output is OFF, Rn will be adjustment, present time is adjustment to 8:01 0second, and Rn output is ON ,after one scan time Rn output is OFF.

Comparator Instructions

The SG2 smart relay includes a total of 15 separate comparator instructions that can be used throughout a program. Each comparator has a choice of 6 operation modes. Additionally, each comparator has 7 parameters for proper configuration. The table below describes each configuration parameter, and lists each compatible memory type for configuring counters.

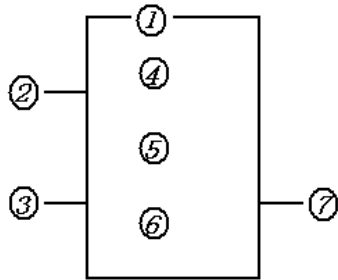

Symbol	Description
①	Comparison Mode(0~5)
②	AX analog input (A1~A8/ V1~V8), the present value of the timer, counter.
③	AY analog input (A1~A8/ V1~V8), the present value of the timer, counter.
④	AX analog input value(0.00~99.99)
⑤	AY analog input value (0.00~99.99)
⑥	Set reference comparative value: could be constant, or the present value of the timer, counter and analog input, analog input (A1~A8/ V1~V8).
⑦	Output terminal(G1~GF)

Analog comparator Mode 0 (Internal Coil)

Mode 0 Analog Comparator used as internal auxiliary coils. No preset value.

In the example below shows the relationship between the numbered block diagram for a Mode 0 Analog Comparator the ladder diagram view, and the software Edit Contact/Coil dialog box.

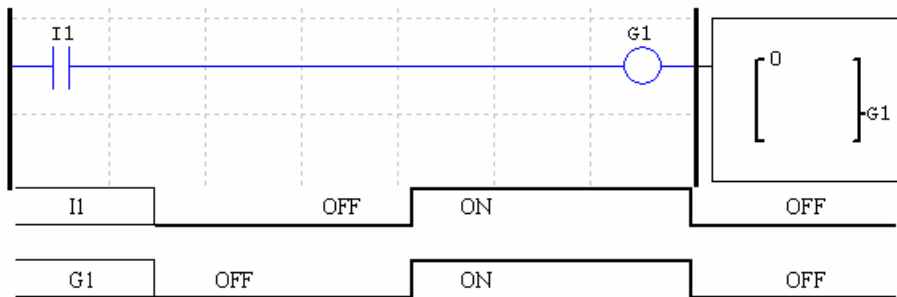
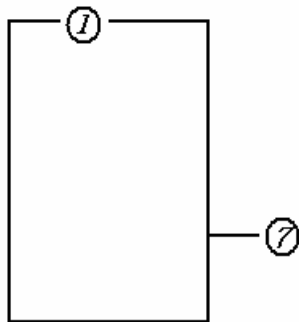
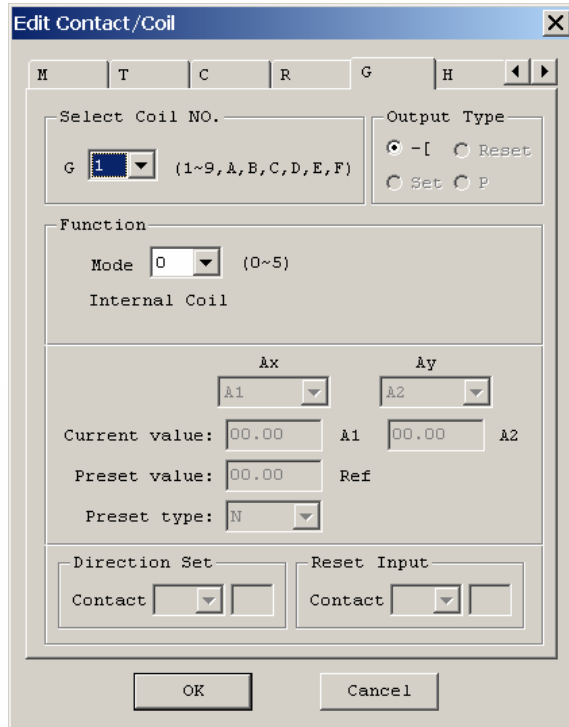

Analog comparator Mode 1~5

When the relay of analog comparator is ON, there are 5 operation modes described below:

- (1) Analog Comparator mode 1 ($AY - \leq AX \leq AY +$, ON)
- (2) Analog Comparator mode 2 ($AX \leq AY$, ON)
- (3) Analog Comparator mode 3 ($AX \geq AY$, ON)
- (4) Analog Comparator mode 4 ($\geq AX$, ON)
- (5) Analog Comparator mode 5 ($\leq AX$, ON)

Example 1: Analog Signal Compare

In the example below, Mode 4 is the selected function that compares the value of analog input A1 to a constant value (N) of 2.50. Status coil G1 turns ON is A1 is \leq to 2.50.

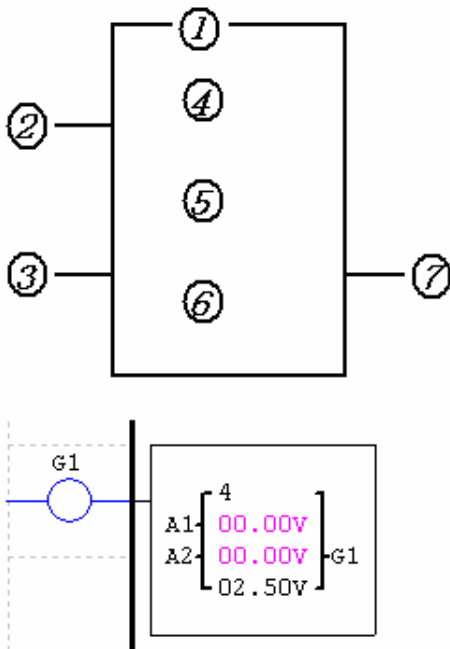

X
Edit Contact/Coil

Select Coil NO. G 1 (1~9, A, B, C, D, E, F)	Output Type <input checked="" type="radio"/> -[<input type="radio"/> Reset <input type="radio"/> Set <input type="radio"/> P
---	---

Function Mode 4 (0~5) Ax <= Reference value
--

Ax A1	Ay A2
Current value: 00.00 A1	00.00 A2
Preset value: 02.50 Ref	
Preset type: N	

Direction Set Contact 	Reset Input Contact
--	--

OK
Cancel

Example 2: Timer/Counter Preset Value Compare

The Comparator instruction can be used to compare Timer, Counter, and RTC values to a constant value or to each other. In this example below, Mode 5 is the selected function that compares the value of Counter (C1) to a constant value (N) of 15 counts (the decimal point is ignored). Status coil G1 turns ON if C1 is to 15 counts.

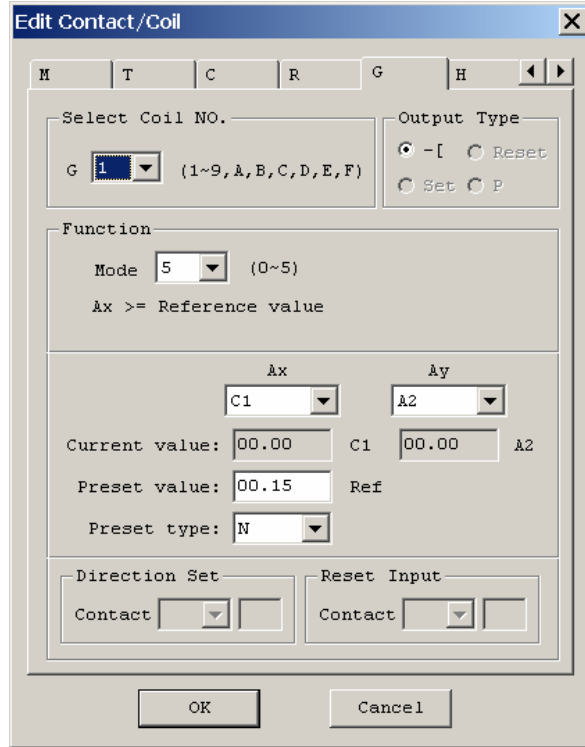
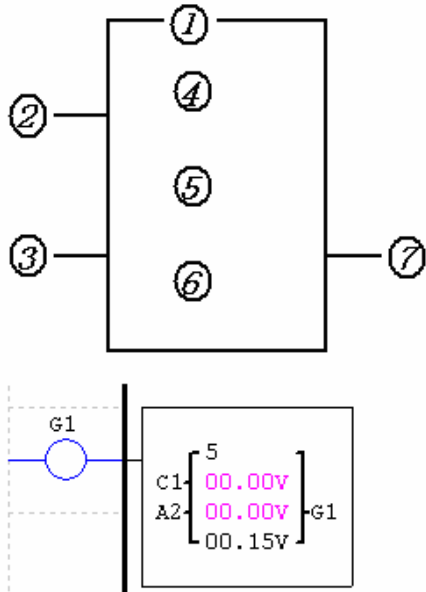

HMI Display Instructions

The SG2 smart relay includes a total of 15 HMI instructions that can be used throughout a program. Each HMI instruction can be configured to display information on the SG2 12x4 character LCD in text, numeric, or bit format for items such as current value and target value for timers/counters, Input/Output bit status, RTC (real time clock) and Analog comparator.

Each HMI instruction is configured separately using the **Edit»HMI/Text** menu selection from the SG2 Client software.

In the adjacent example, HMI instruction H1 is configured to display the value of I1 and T1, and some descriptive text. Numeric display data selections are Timer, Counter, RTC, and Analog. Bit display data selections for “ON” and “OFF” messages are “I” inputs, “M” internal relays, “X” expansion inputs and “Z” keypad inputs.

Allows the SEL button on the SG2 keypad to activate the selected message onto the LCD even when Hx coil is inactive.



T1 Current (unit)

T1 Current

Allows the HMI message to include coil number and selected value (i.e. T1=003 sec).

Analog Display Set...

Provides access to the Analog Display Set dialog for gain and offset parameters shown below.

The Analog Display Set dialog allows the user to specify a scaling factor (Gain) and an offset for each analog input value.

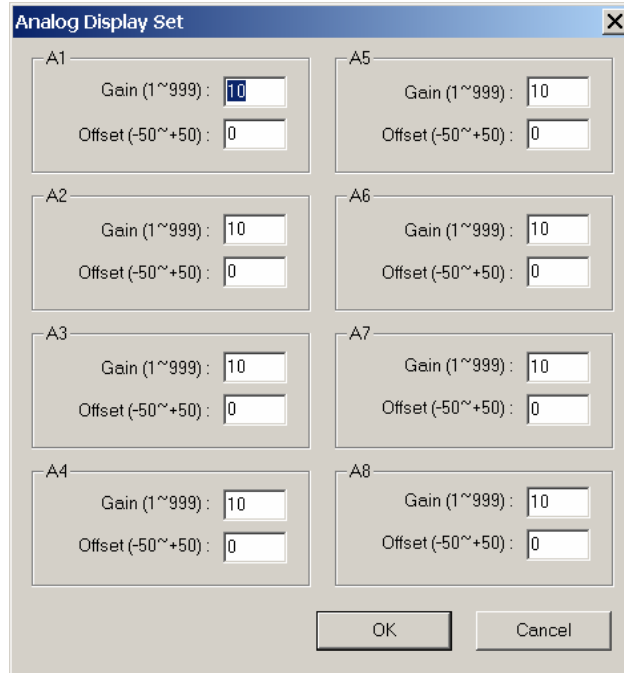

Phone Number

18009720436

Add

A phone number can be displayed on the screen to alert an operator to call for help.



Note: The Phone Number field does not dial a modem or allow for a modem connection.

Each HMI instruction has a choice of 2 operation modes. The table below describes each configuration parameter.

Symbol	Description
①	Display Mode (1-2)
⑤	HMI character output terminal (H1-H8)

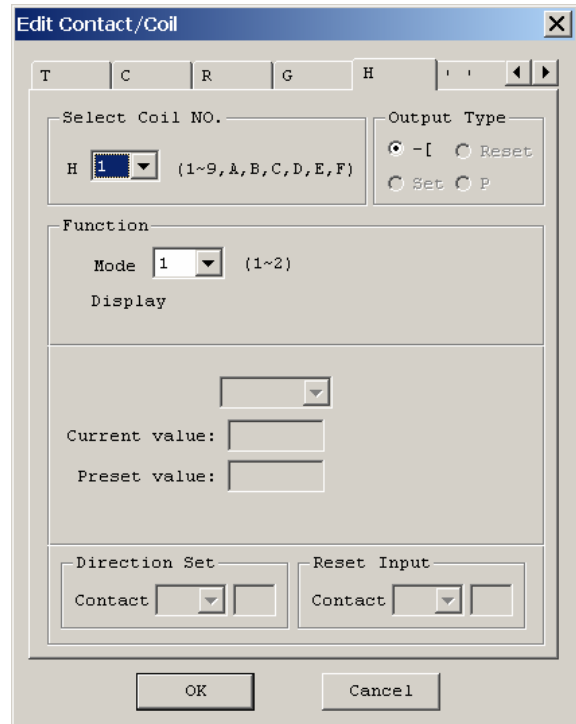
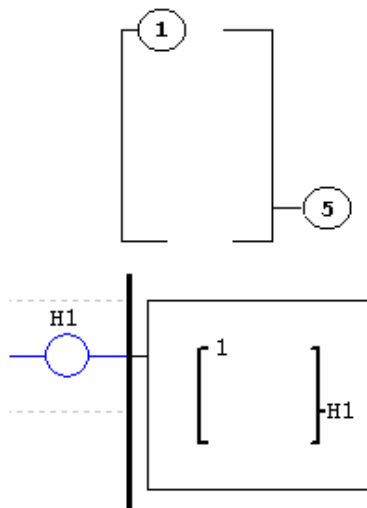

PWM Output Instruction (DC Transistor Output Models Only)

The transistor output model smart relay includes the capability to provide a PWM (Pulse Width Modulation) output on terminal Q1. The PWM instruction is able to output up to an 8-stage PWM waveform.

Symbol	Description
①	Set display stages (1~8)
②	Display the present stage as operation(0~8)
③	Input Selected Stage 1(I1~gF)
④	Input Selected Stage 2(I1~gF)
⑤	Input Selected Stage 3(I1~gF)
⑥	Set PWM pulse width (0~32768ms)
⑦	Set PWM Period(1~32768ms)
⑧	PWM output terminal P1

Enable					Output PWM
OFF	X	X	X	0	OFF
ON	OFF	OFF	OFF	1	Set stage 1
ON	OFF	OFF	ON	2	Set stage 2
ON	OFF	ON	OFF	3	Set stage 3
ON	OFF	ON	ON	4	Set stage 4
ON	ON	OFF	OFF	5	Set stage 5
ON	ON	OFF	ON	6	Set stage 6
ON	ON	ON	OFF	7	Set stage 7
ON	ON	ON	ON	8	Set stage 8

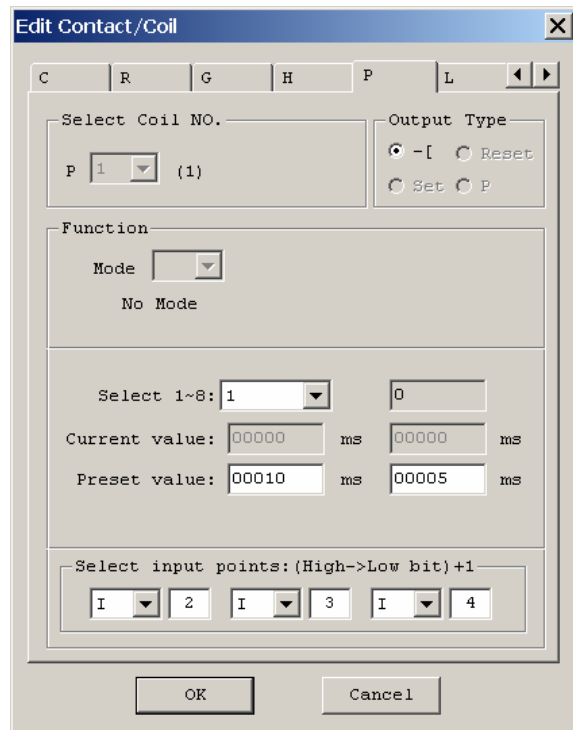
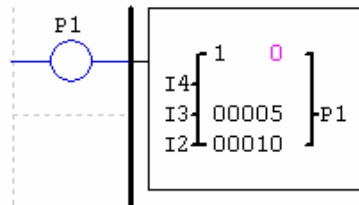
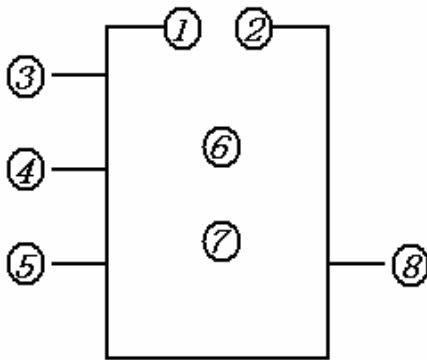

Data Link/Remote I/O Instruction (SG2-20Vxx Models Only)

The SG2-20Vxxx transistor output models include the capability to link additional SG2-20Vxx units via the RS-485 connection terminals.

Up to 8 additional SG2 units can be configured as independent Slave nodes, each running their own logic program and their I/O linked to one Master smart relay.

Up to 2 additional SG2 units can be configured as Remote I/O nodes, and linked to one Master smart relay.

Symbol	Description
①	Mode setting (1, 2) 1:sending 2:receiving
②	Set the send/receive points(1-8)
③	Set the send/receive points
④	Send/receive memory list location
⑤	I/O link output terminal (L1-L8)

Selectable Points	Range
Inputs	I1-IC / i1-iC
Outputs	Q1-Q8 / q1-q8
Auxiliary coil	M1-MF / m1-mF
Expansion inputs	X1-XC / x1-xC
Expansion outputs	Y1-YC / y1-yC

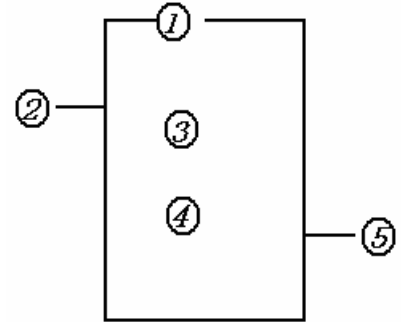

Note: Only one “Mode 1 Send” Data Link instruction (L1-L8) is allowed per Master smart relay. All other Data Link instructions must be “Mode 2 Receive” instructions.

ID	Memory List Location
0	W1~W8
1	W9~W16
2	W17~W24
3	W25~W32
4	W33~W40
5	W41~W48
6	W49~W56
7	W57~W64

The Mode 2 Receive memory range is determined by the Controller ID. Each controller ID is allocated a range of 8 I/O points (Wx-Wx) that can be read into the Master smart relay using a DataLink instruction. The adjacent table show the memory range of Wx locations associated with each controller ID.

The Data Link instruction below is setup for Mode 1 Send where the Master smart relay is sending 5 I/O points of Inputs to each connected Slave smart relay. The starting Input is I03 with the resulting range of 5 sending inputs equal to I3 – I7.

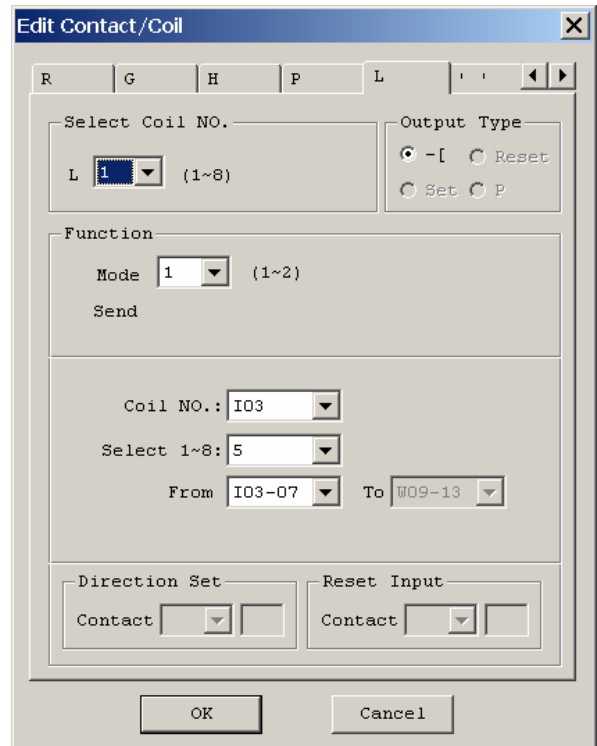
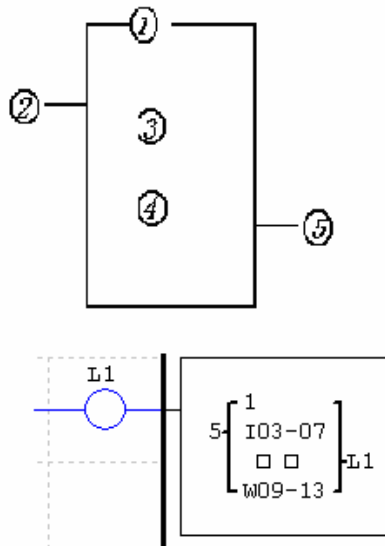

Example 1: Data Link Mode 1

Set = 1, = 5, set as the initiate of I3, the state of actual sending terminal I3~I7 is sent to memory list; the controller ID = 3, the state of corresponding memory list position W25~W32, and relationship of sending terminal is as below:

	①=1, ②=5, ③=I3~I7, ID=3(④: W25~W32)							
Memory List Position	W25	W26	W27	W28	W29	W30	W31	W32
Corresponding receiving or sending terminal	↑	↑	↑	↑	↑	↑	↑	↑
	I3	I4	I5	I6	I7	0	0	0

Example 2: Data Link Receive mode 2

Set = 2, = 5, set as start from M3, set as start from W17, when enabling the Data Link, the state 'ON/OFF' of M3~M7 is controlled by the state of memory list position W17~W21.

	①=2, ②=5, ③=M3~M7, ④:W17~W21				
Memory List Position	W17	W18	W19	W20	W21
Corresponding receiving or sending terminal	↓	↓	↓	↓	↓
	M3	M4	M5	M6	M7

Chapter 5: Function Block Diagram Programming

FBD Instructions

Note: FBD program can only be edited and modified in SG2 Client software and write to SG2 controlled equipments via communication cable. Via controlled equipment, FBD program is available for querying or the parameter of the function block of the program for modifying.

Function Block	Input	Output Coil	Range
Input	I		I01~I0C(12)
Keypad input	Z		Z01~Z04 (4)
Expansion Input	X		X01~X0C(12)
Output	Q	Q	Q01~Q08(8)
Expansion Output	Y	Y	Y01~Y0C(12)
Auxiliary	M	M	M01~M0F(15)
Knob	N	N	N01~N0F(15)
HMI		H	H01~H0F(15)
PWM		P	P01(1)
SHIFT		S	S01(1)
I/O LINK		L	L01~L08(8)
Logic /Function	B		B01~B99(99)
Normal ON	Hi		
Normal OFF	Lo		
No Connection	Nop		

Coil Block Instruction

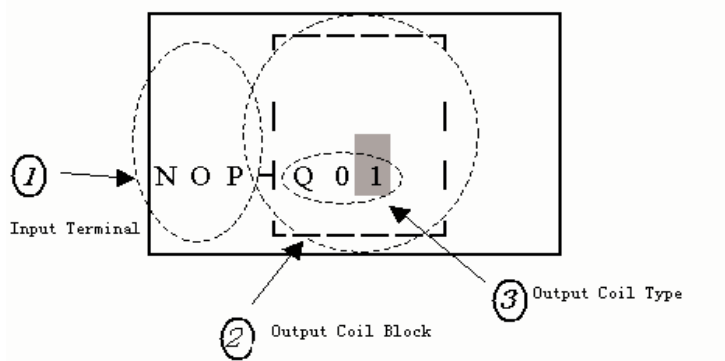

PWM Function Block

The PWM output terminal 'Q1' can output 8 PWM waveforms. (Only provided for transistor output version)

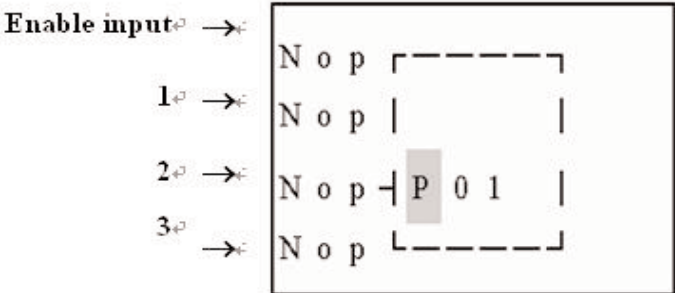

PWM Function [X]

Function

Sw3	Sw2	Sw1	T (ms)	t (ms)
0	0	0	1	0
0	0	1	1	0
0	1	0	1	0
0	1	1	1	0
1	0	0	1	0
1	0	1	1	0
1	1	0	1	0
1	1	1	1	0

Symbol:

OK Cancel

PO1

P

SHIFT Function Block

Input terminal description

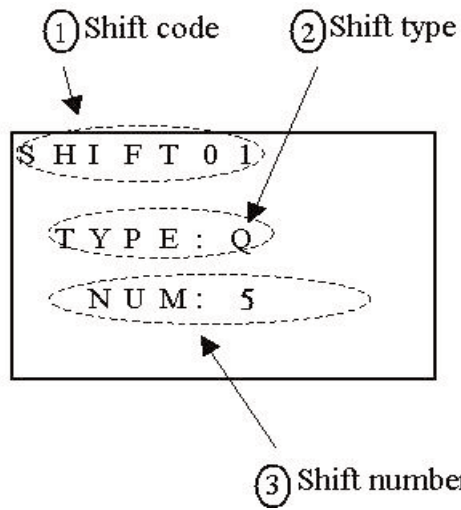
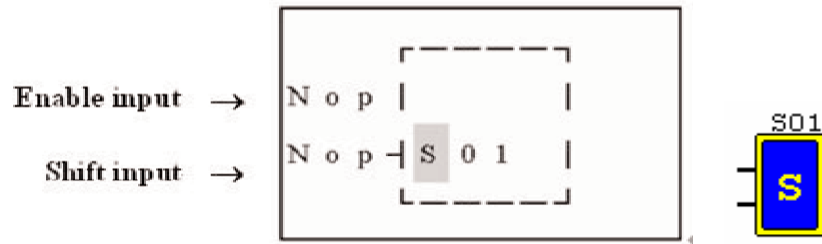

Symbol	Description
①	SHIFT code (Total 1 group)
②	Set output type (Q, Y)
③	Set output shift number (1-8)

② = Q , ③ = 5 Shift output range: Q1~Q5

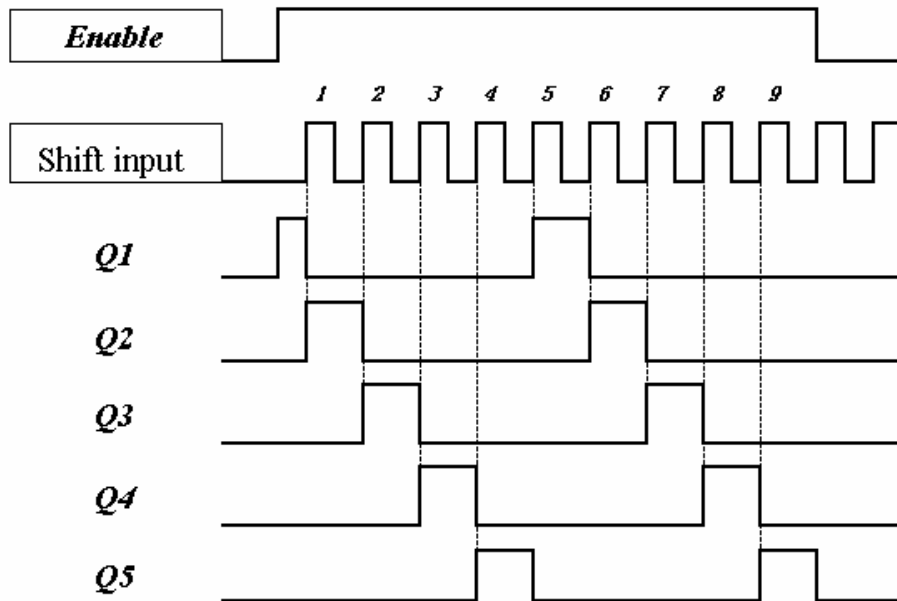

Logic Block Instructions

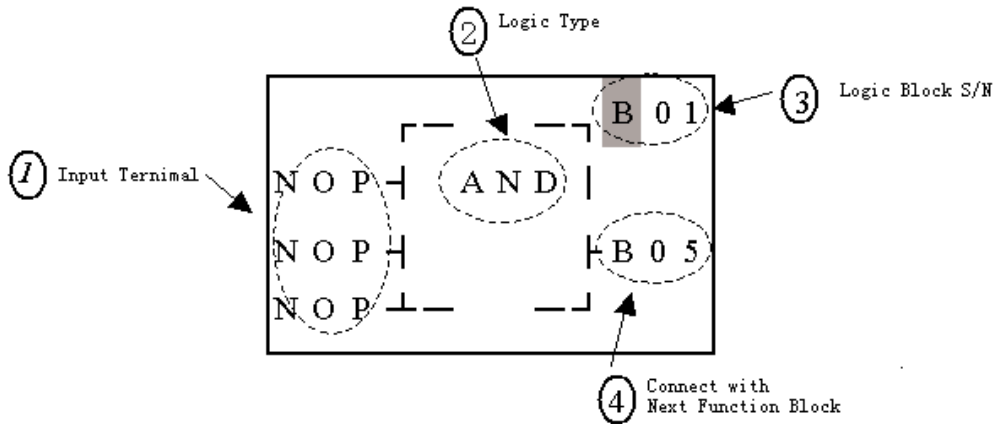

AND Logic Diagram

FBD:

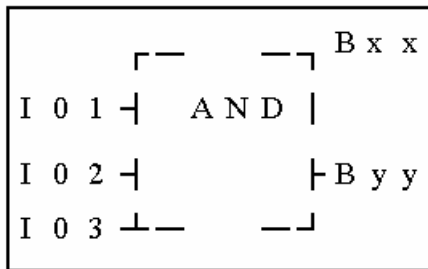

I01 And I02 And I03

Note : The input terminal is NOP which is equivalent to 'Hi'

LADDER:

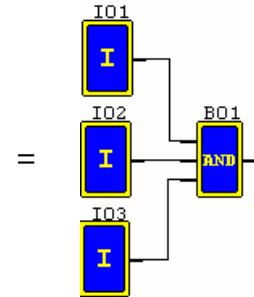
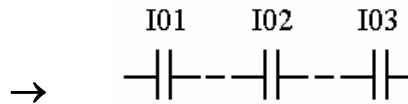

AND (EDGE) Logic Diagram

FBD:

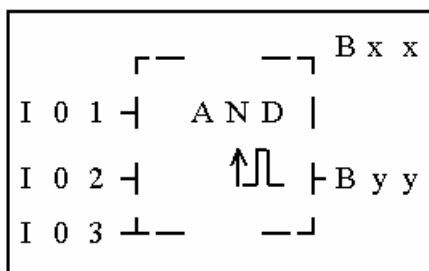

I01 And I02 And I03 And D

Note : The input terminal is NOP which is equivalent to 'Hi'

LADDER:

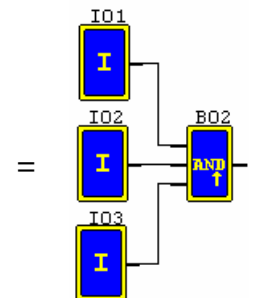
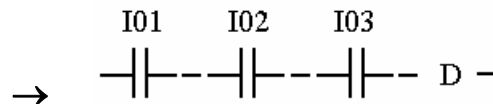

NAND Logic Diagram

FBD:

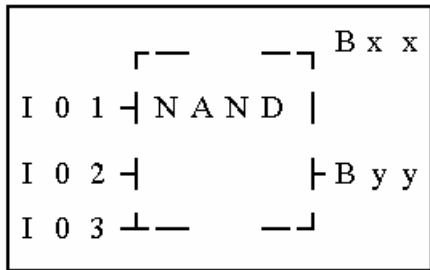

LADDER:

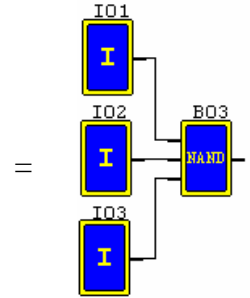
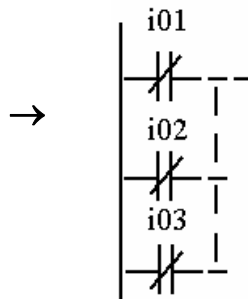

Not(I01 And I02 And I03)

Note : The input terminal is NOP which is equivalent to 'Hi'

NAND (EDGE) Logic Diagram

FBD:

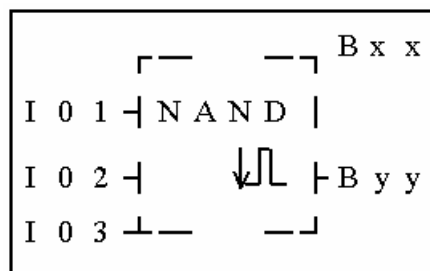

LADDER:

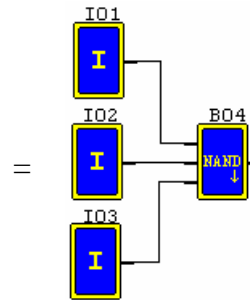
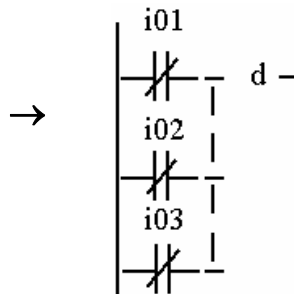

Not(I01 And I02 And I03) And d

Note : The input terminal is NOP which is equivalent to 'Lo'

OR Logic Diagram

FBD:

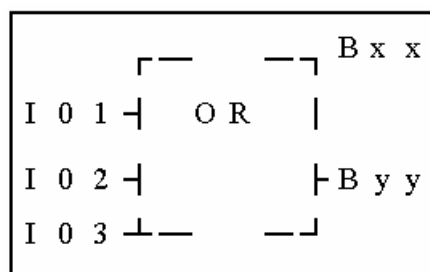

LADDER:

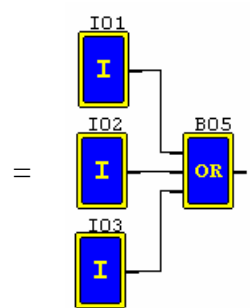
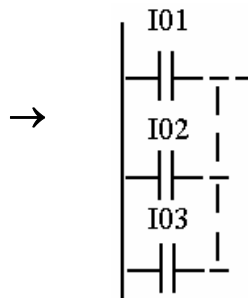

I01 or I02 or I03

Note : The input terminal is NOP which is equivalent to 'Lo'

NOR Logic Diagram

FBD:

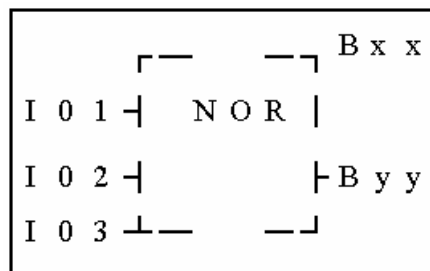

LADDER:

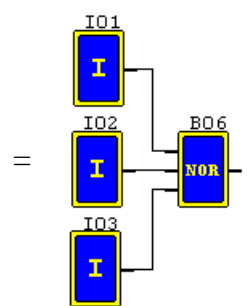
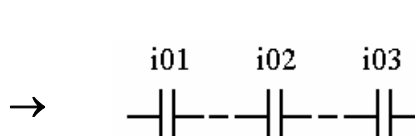

Not (I01 or I02 or I03)

Note : The input terminal is NOP which is equivalent to 'Lo'

XOR Logic Diagram

FBD:

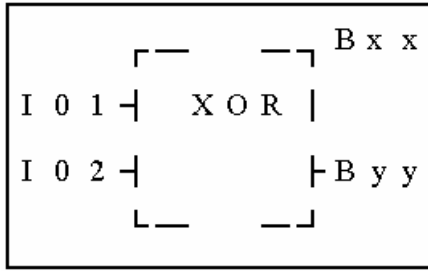

I01 Xor I02

Note : The input terminal is NOP which is equivalent to 'Lo'

LADDER:

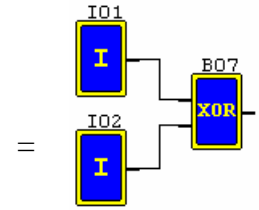
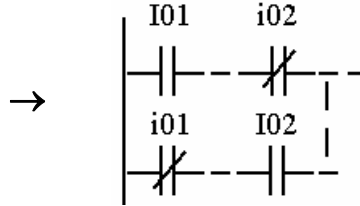

SR Logic Diagram

FBD:

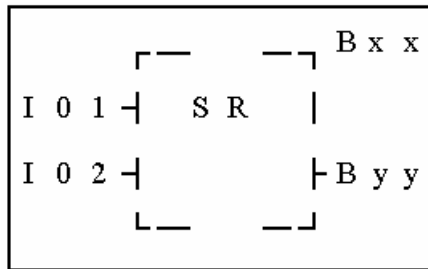

Logic Table	I01	I02	Bxx
	0	0	holding
	0	1	0
	1	0	1
	1	1	0

Note : The input terminal is NOP which is equivalent to 'Lo'

LADDER:

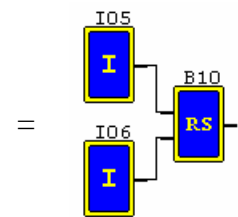
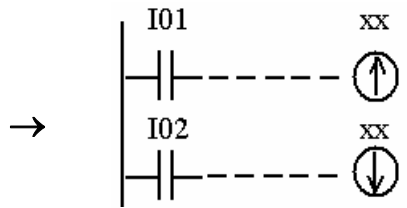

NOT Logic Diagram

FBD:

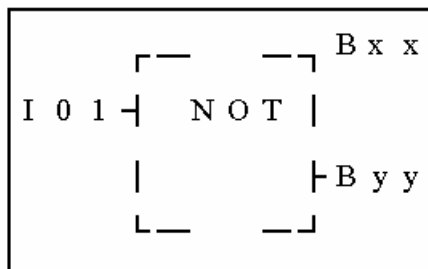

Not I01

Note : The input terminal is NOP which is equivalent to 'Hi'

LADDER:

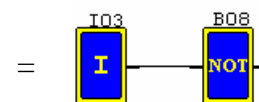
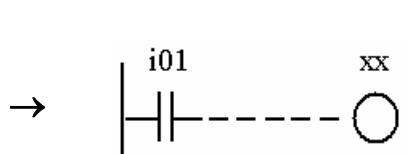

Pulse Logic Diagram

FBD:

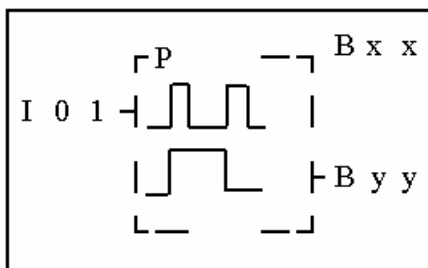

LADDER:

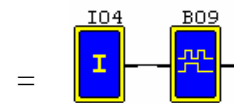
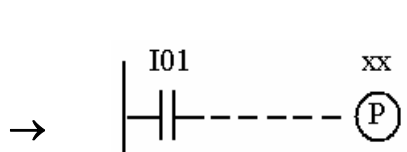

Note : The input terminal is NOP which is equivalent to 'Lo'

Function Block

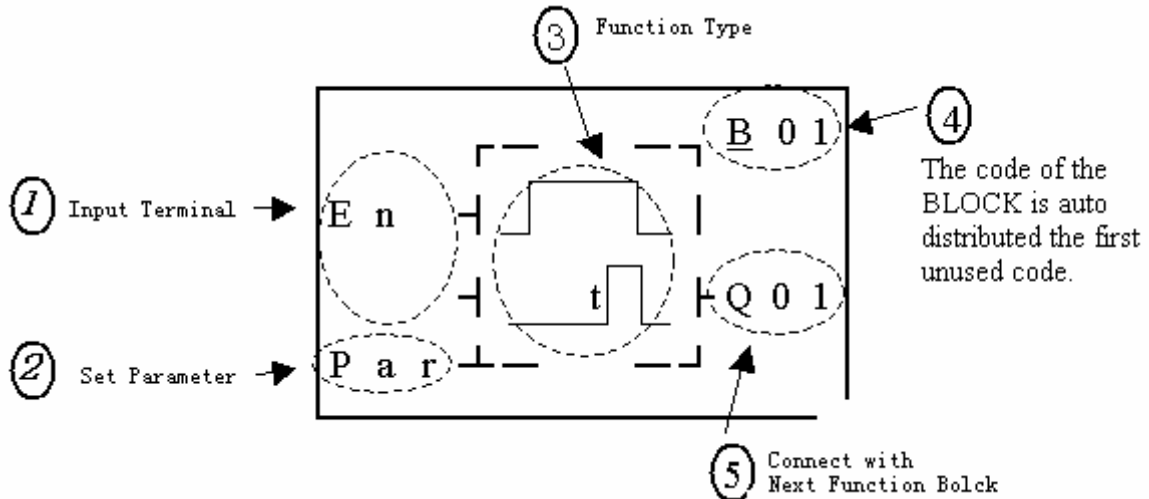

The function blocks are classified into 4 sorts: Time, Counter, RTC Comparator 'R' and Analog Comparator 'G'. The Operation Fundamental is similar to LADDER Function Block's.

Common Counter Function Block

(1) Counter Mode 1

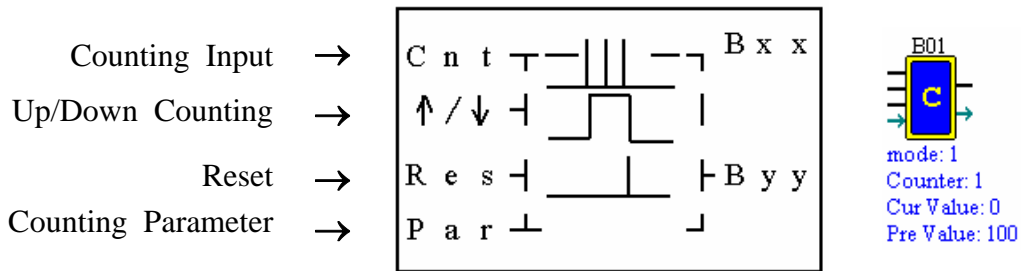

(2) Counter Mode 2

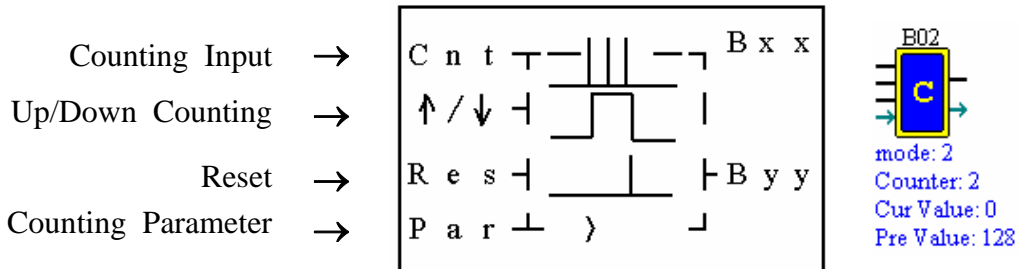

Note: The ">" means the current value appeared will be greater than present value.

(3) Counter Mode 3

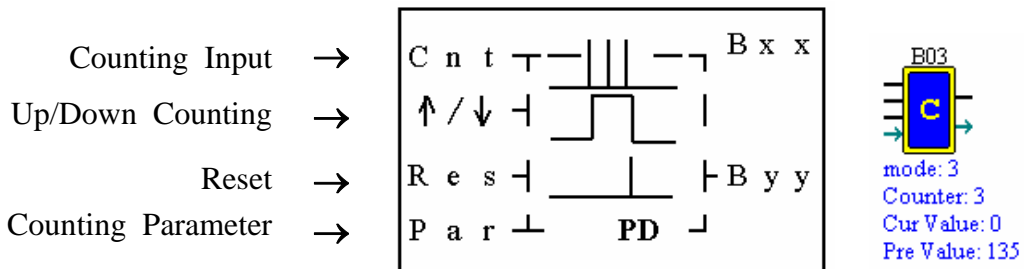

Note: The "PD" means the current value will be retain until the power recover.

(4) Counter Mode 4

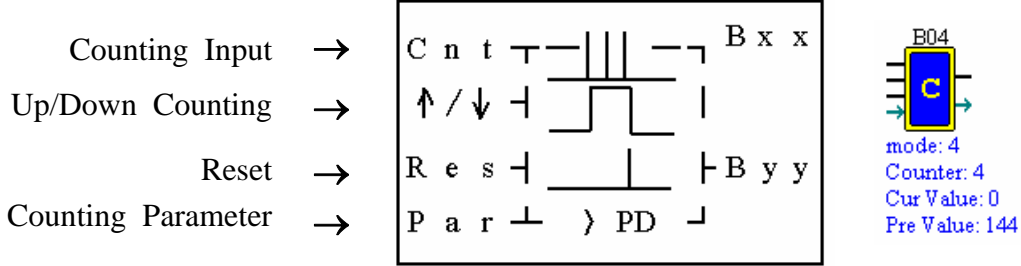

(5) Counter Mode 5

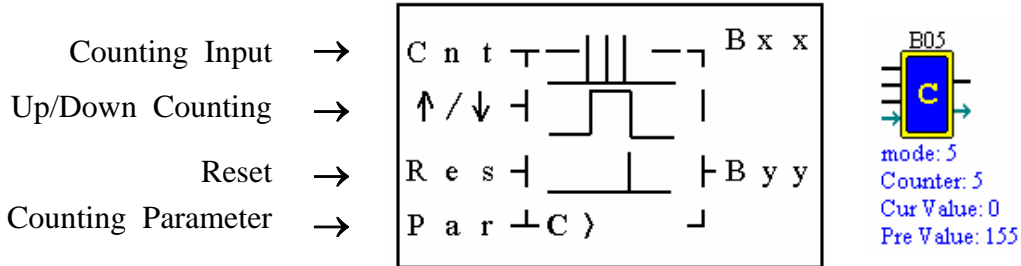

Note: The “C” means that will keep the current value in 0 during the Reset pin be enable.

(6) Counter Mode 6

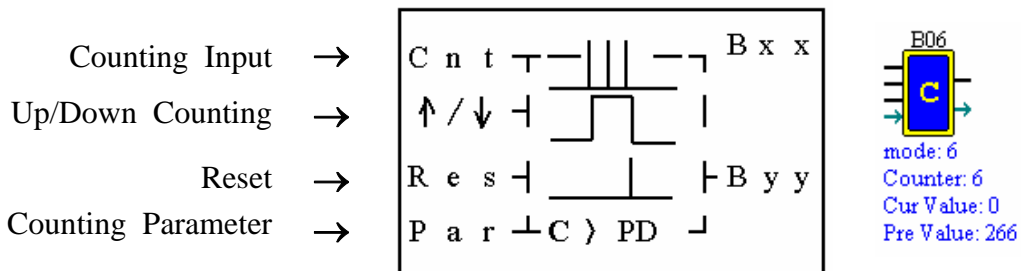

High Speed Counter Function Block

(1) Counter Mode 7

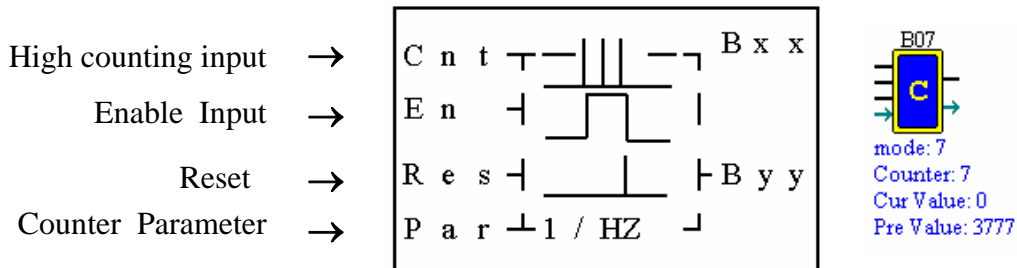

Note : High speed input terminal I1,I2

(2) Counter Mode 8

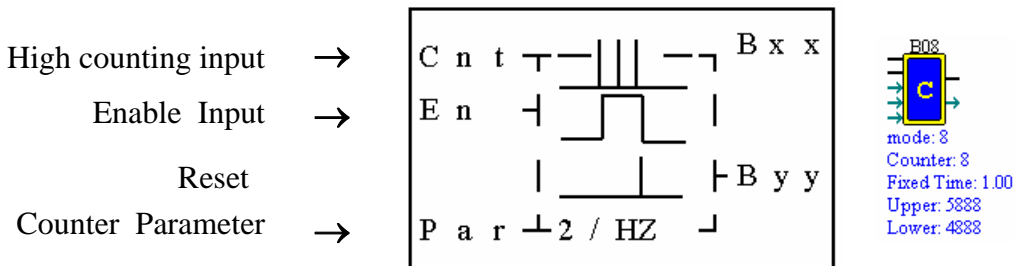

Note : High speed input terminal I1,I2

Timer Function Block

(1) Timer mode 0 (Internal coil Mode)

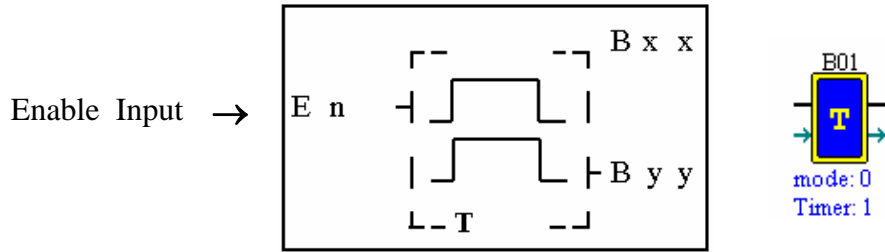

(2) Timer mode 1 (ON-Delay A Mode)

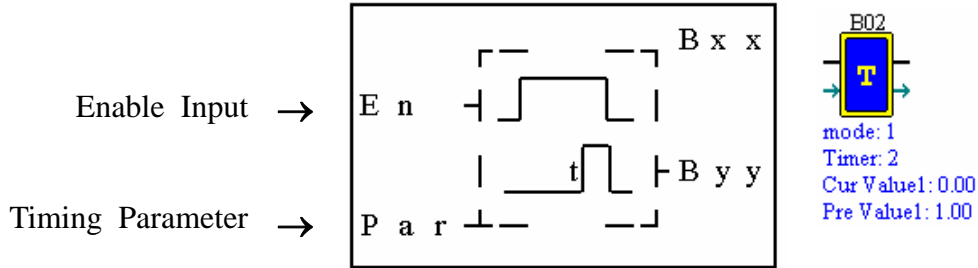

(3) Timer mode 2 (ON-Delay B Mode)

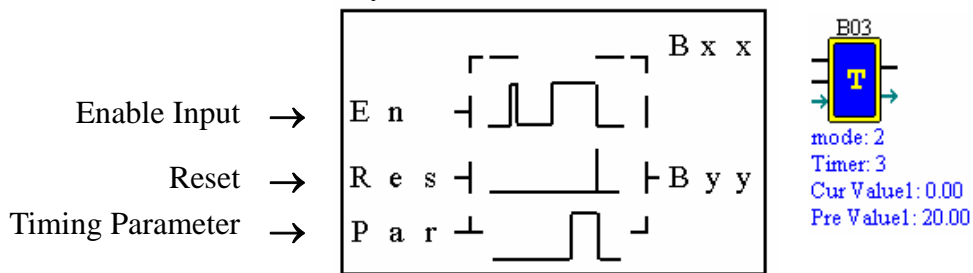

(4) Timer mode 3 (OFF-Delay A Mode)

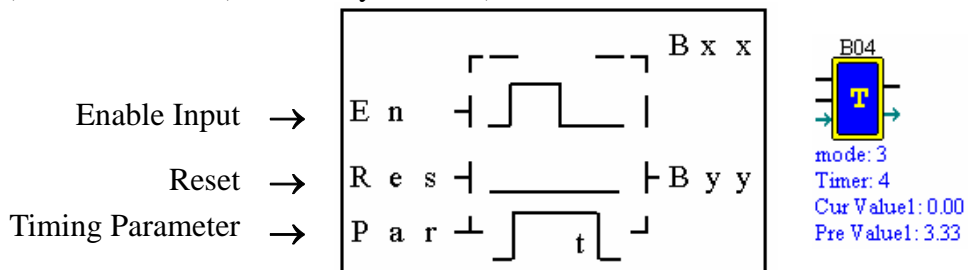

(5) Timer mode 4 (OFF-Delay B Mode)

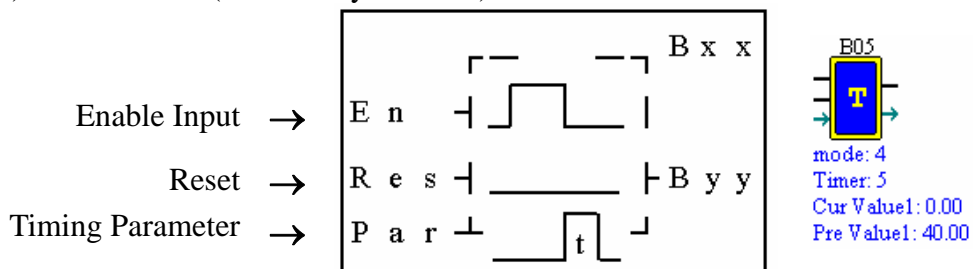

(6) Timer mode 5(FLASH A Mode)

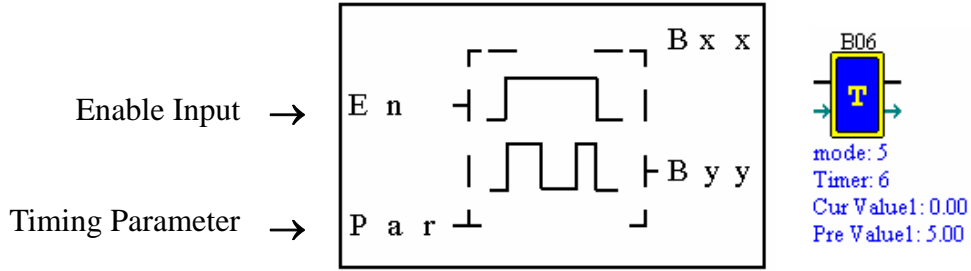

(7) Timer mode 6(FLASH B Mode)

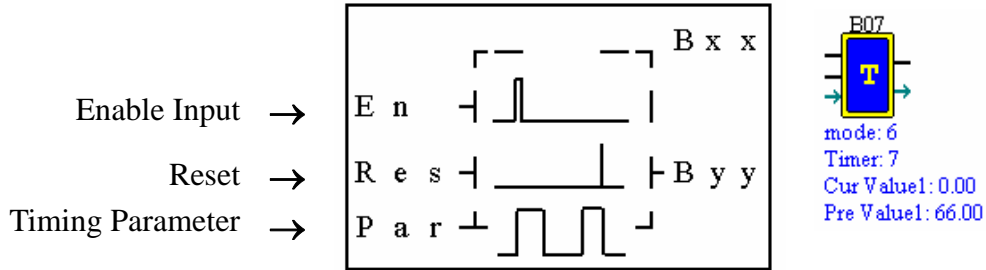

(8) Timer mode 7(FLASH C Mode)

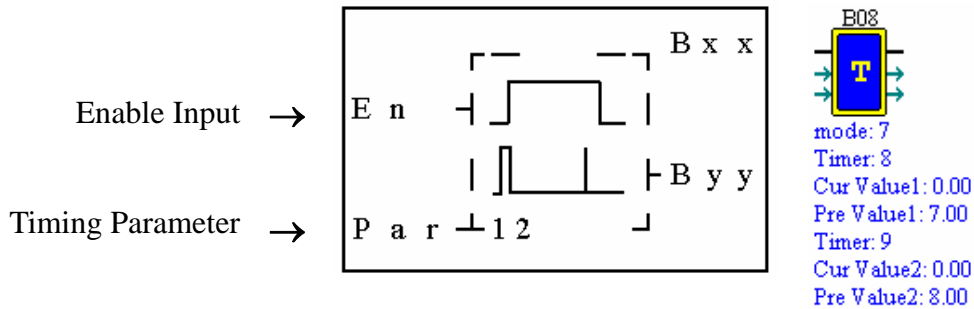

RTC Comparator Function Block

(1) RTC Mode 0(Internal Coil)

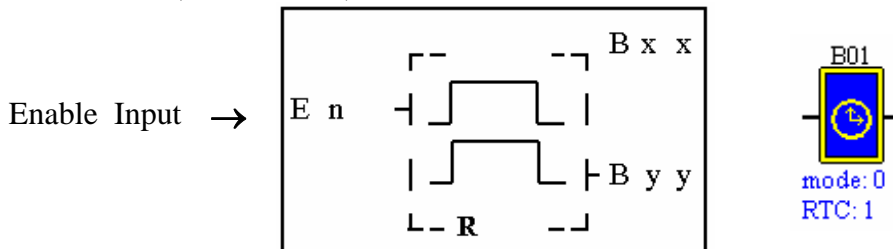

(2) RTC Mode 1(Daily)

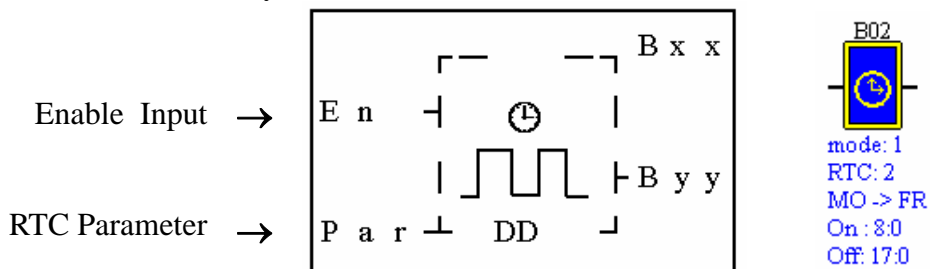

(3) RTC Mode 2 (Continuous)

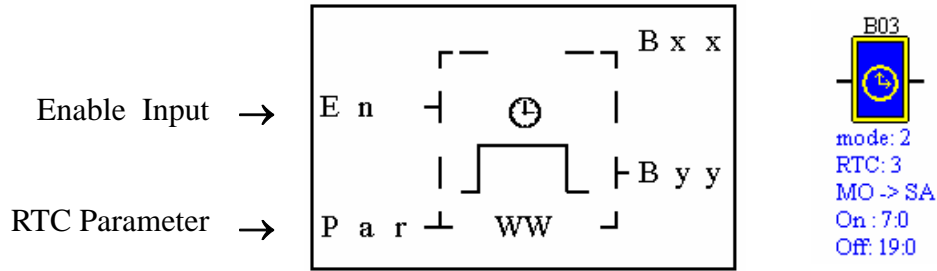

(4) RTC Mode 3 (Year Month Day)

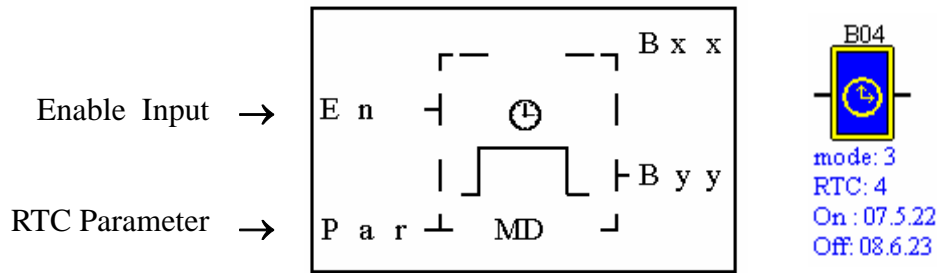

(5) RTC Mode 4(30-second adjustment)

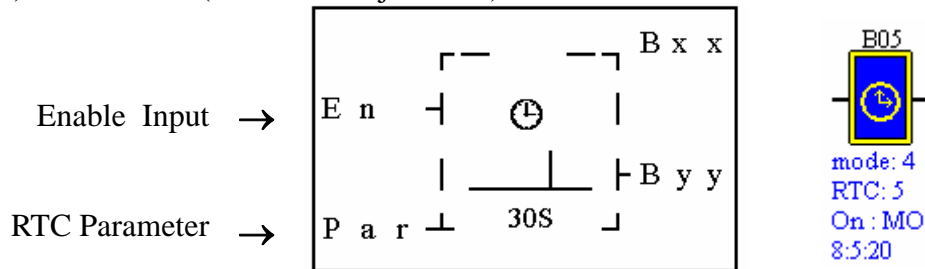

Analog Comparator Function Block

(1) Analog Comparison Mode 0 (Internal coil)

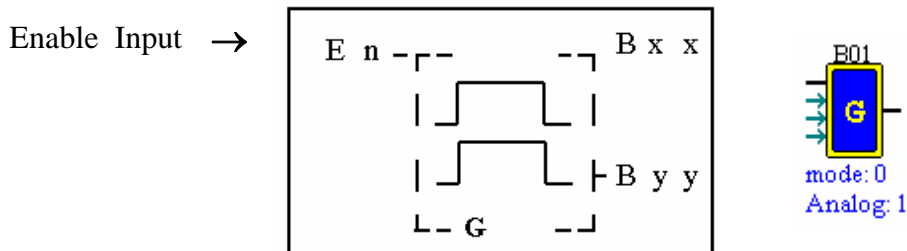

(2) Analog Comparison Mode 1

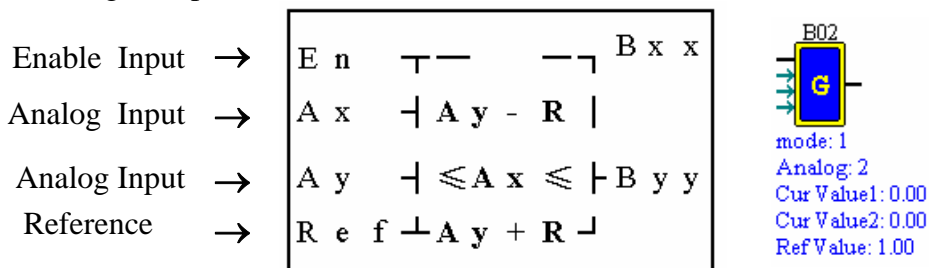

(3) Analog Comparison Mode 2

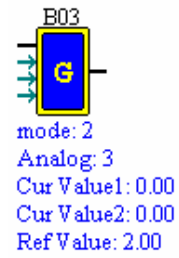
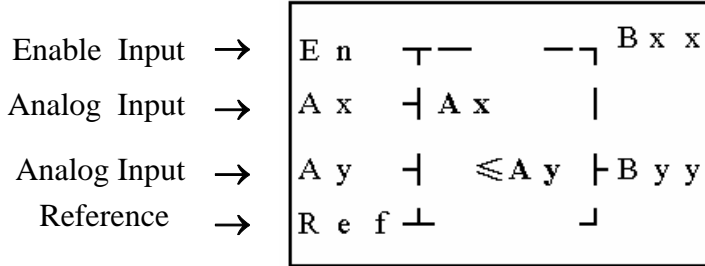

(4) Analog Comparison Mode 3

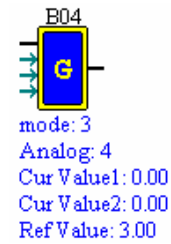
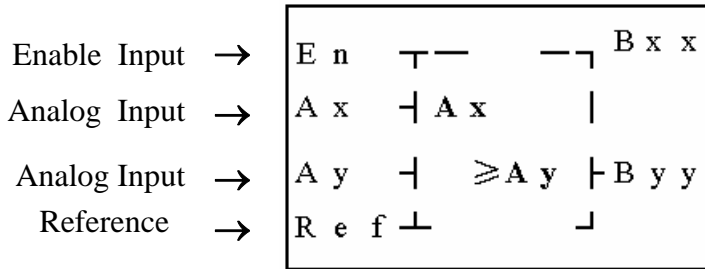

(5) Analog Comparison Mode 4

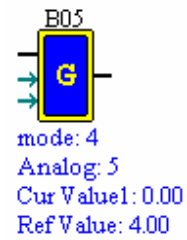
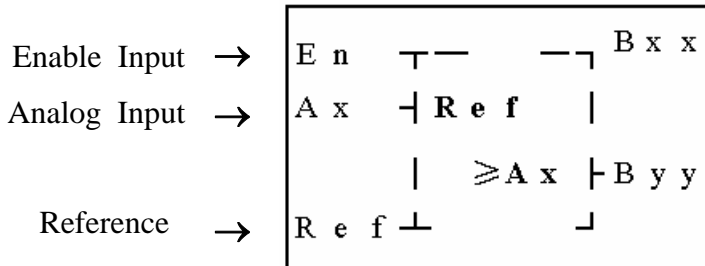

(6) Analog Comparison Mode 5

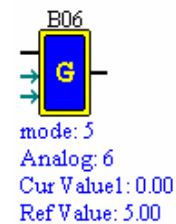
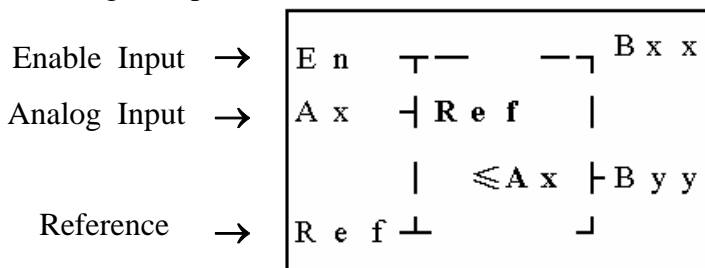

Appendix Application Illustration

1. Lighting Control for Staircase

1.1 Requirement for Staircase Lighting

- When someone goes up-stair or down-stair, the lighting system shall be energized to provide sufficient luminance.
- After the walker passes the staircase, lighting system shall be turned off in five minutes automatically or manually.

1.2 Traditional Lighting Control

There are two traditional controls available:

- Apply pulse relay
- Apply automatic timer to control the lighting system on the staircase

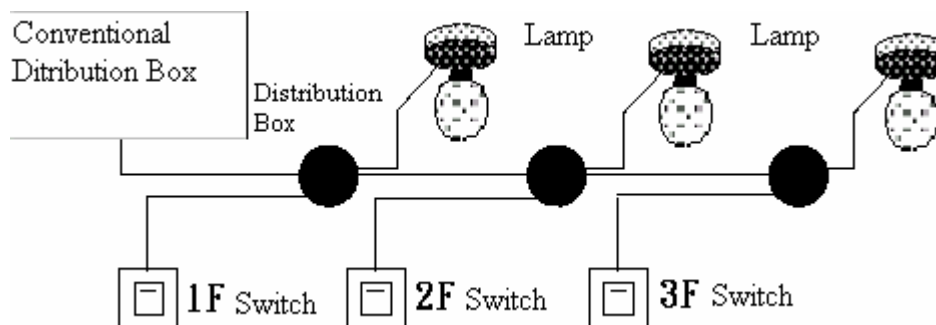

Components Applied

Switches

Auto lighting system or pulse relay for staircase

Applying the pulse relay as controller for staircase lighting system

- The lighting is on as long as any switch is turned on.
- Press any switch again to turn off the lighting system.

Shortcoming: It is a frequent weak point for the person to forget turning off the light at most cases.

Auto lighting control system for the staircase

- The light is on whenever the switch is turned on.

Lighting system shall be turned off in a few minutes automatically or manually

Shortcoming: The user has no way to reset the turn-off time.

1.3 Apply SG2 in Lighting System

Devices Applied

- Q1 Lamp H1
- I1(No terminal) Switch B1
- I2(No terminal) Infrared sensor for climbing

Wiring Diagram for Lighting System

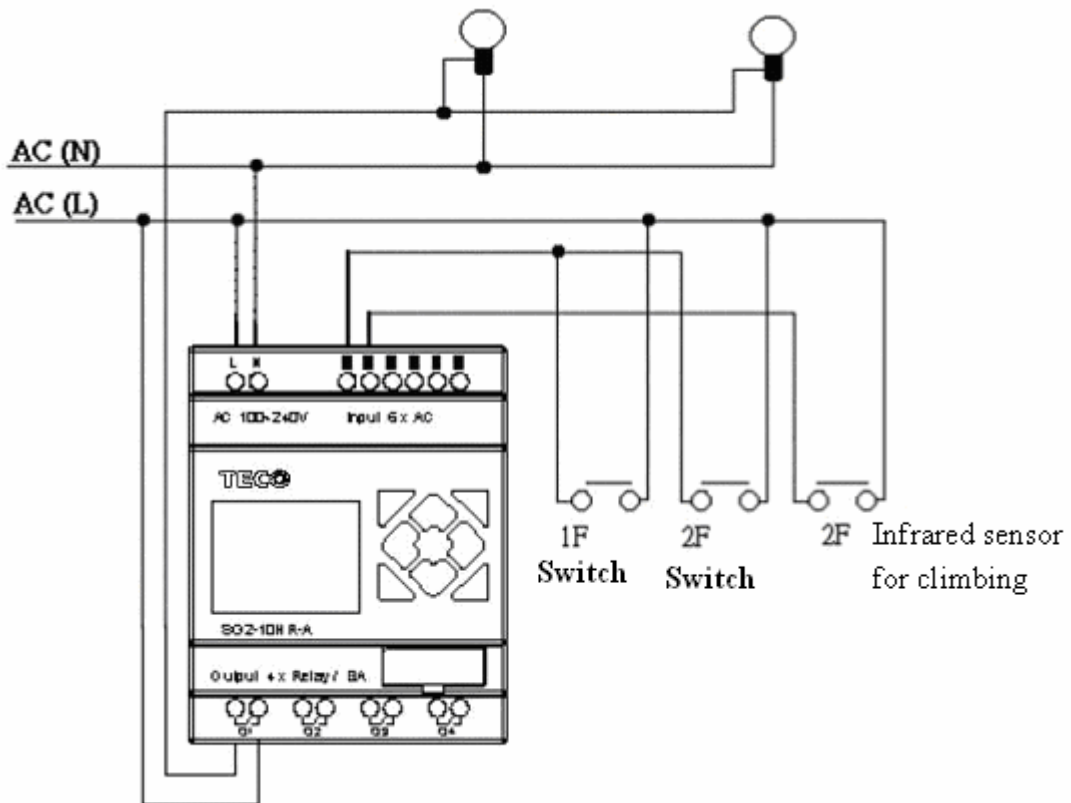

Illustrated program using SG2 in lighting system

Ladder & FUNCTION :

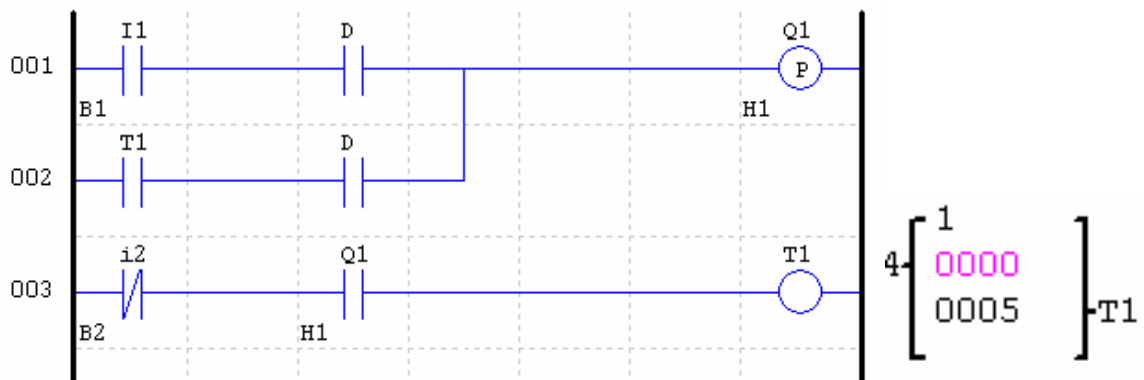

FBD :

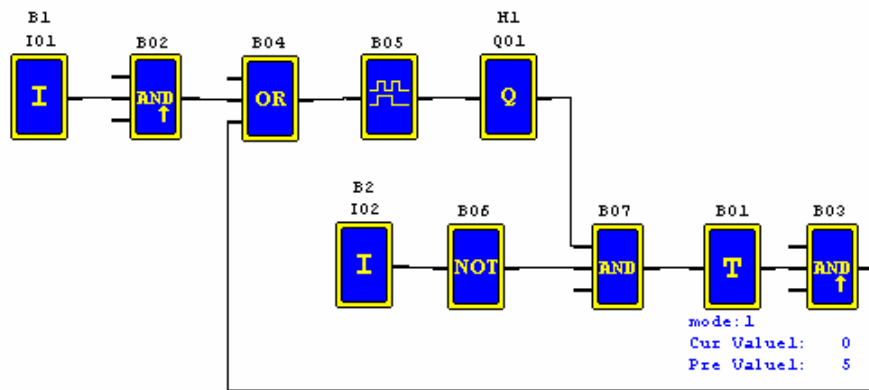

2 Auto Door Control

The auto doors are very popularly installed at the entrance of supermarkets, mansions, banks and hospitals.

2.1 Requirement for Auto Door Control

- It automatically opens whenever a person is approaching.
- The door remains open for a certain period and closes if no visitor is present.

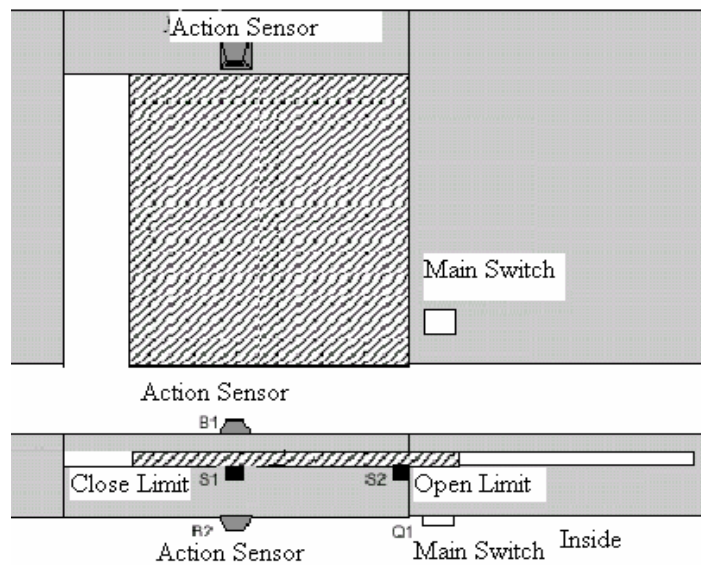

2.2 Traditional solution

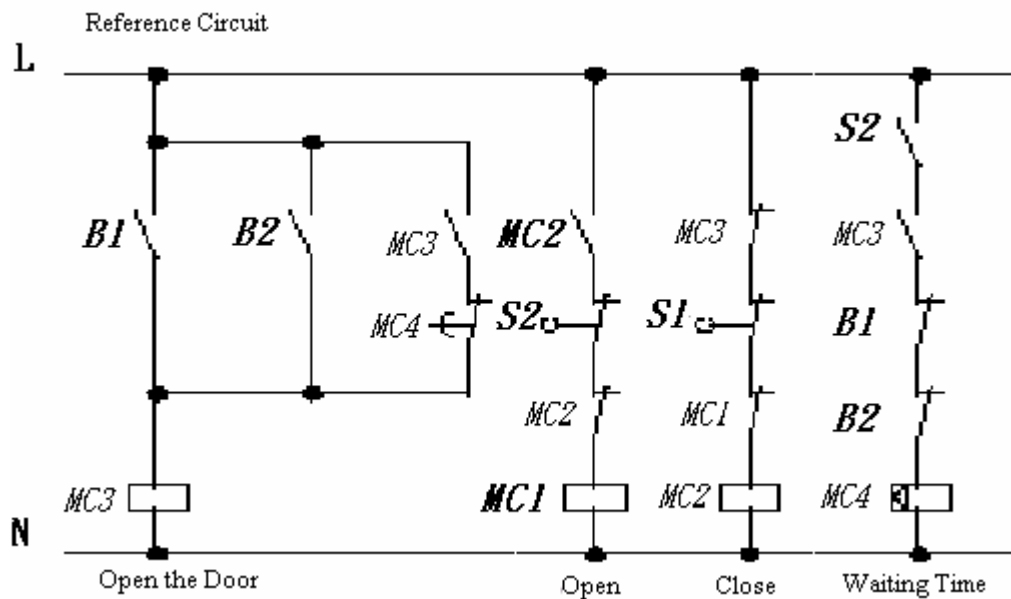

Whenever B1 or B2 senses the approach of a visitor, the door is actuated to open. After an elapse of time, B1 or B2 senses no presence of a visitor; MC4 will close the door.

2.3 Apply SG2 in Door Control System

Applying SG2 in door control system can simplify the circuit. All that one need to do is connect the action sensor, limit switch and contactor with SG2.

Devices Applied

MC1 main door open contactor

MC2 main door close contactor

S1(NC contact) closing limit switch

S2(NC contact) opening limit switch

B1(NO contact) outdoor infrared sensor

B2(NO contact) indoor infrared sensor

Wiring Diagram and Program with SG2 applied in door control system.

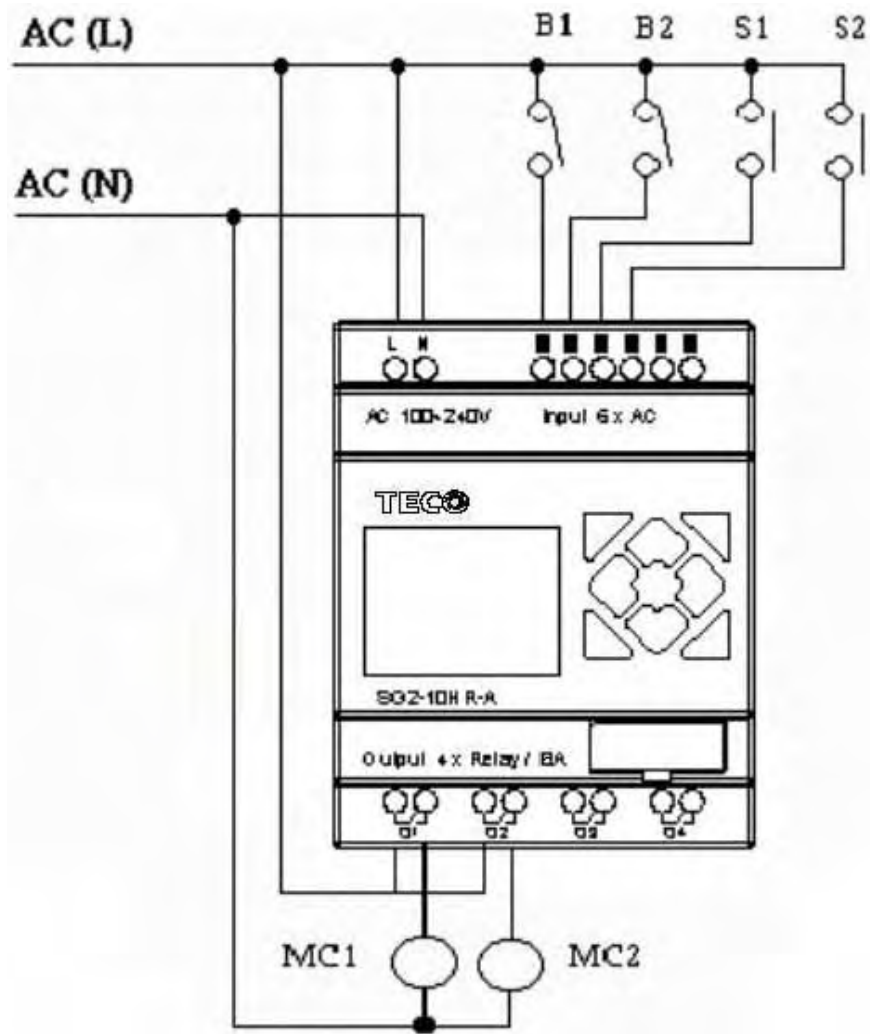

Ladder & FUNCTION :

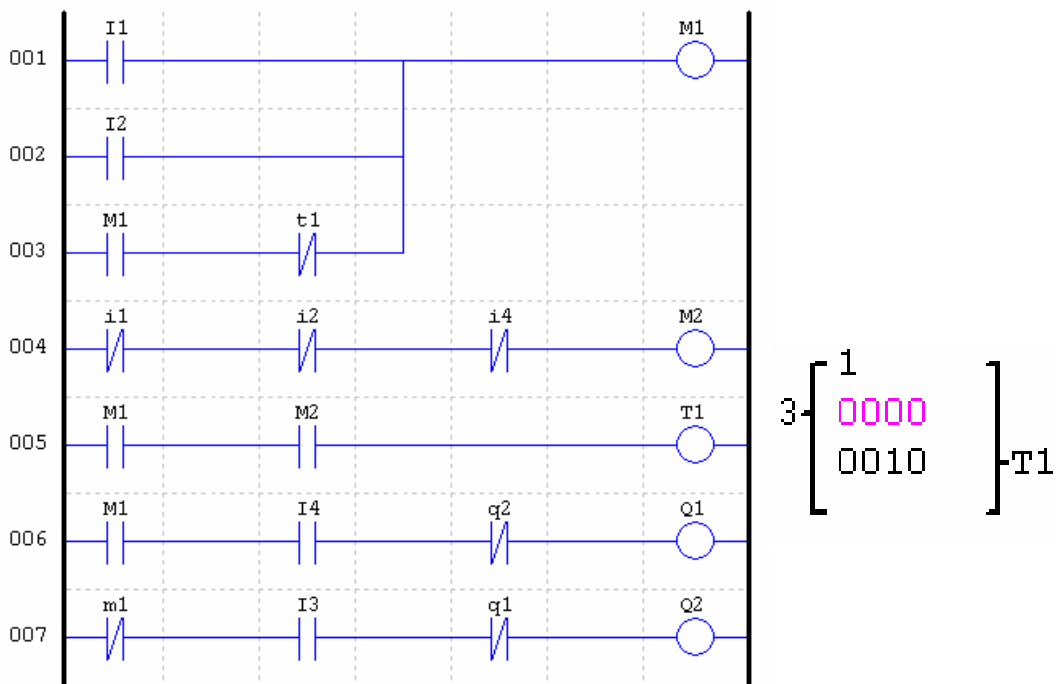

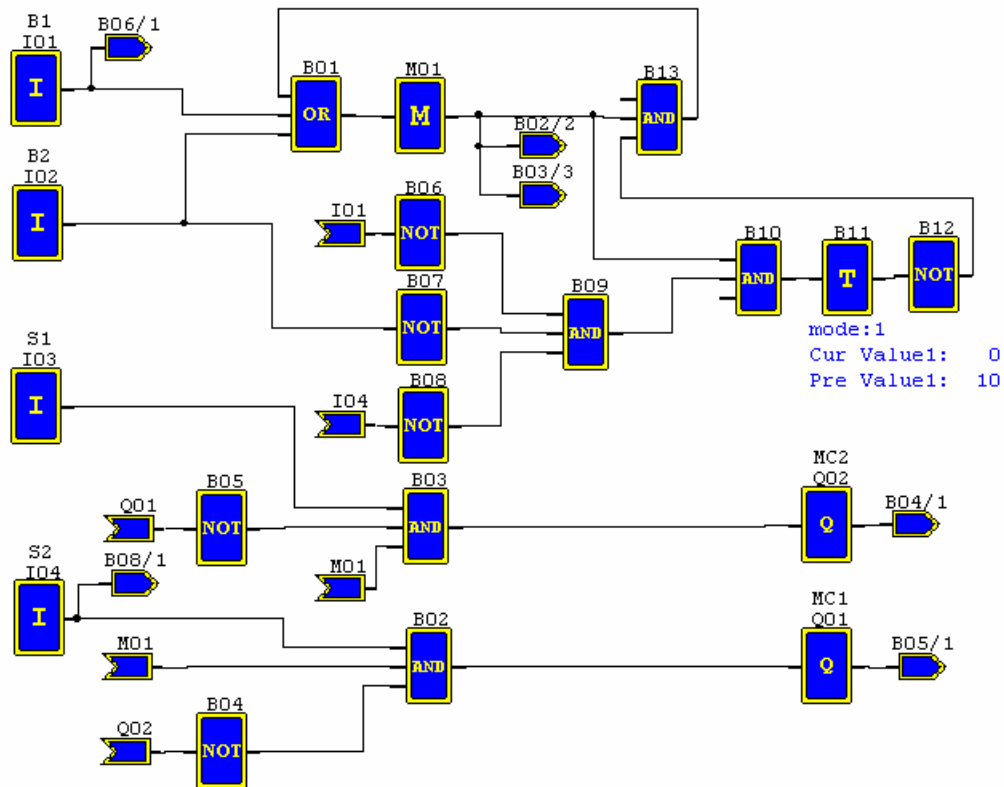
FBD Operation Flow :**3. Ventilation Control****3.1 Ventilation System Requirement**

The main function of the ventilation system is to blow in the fresh air and blow out the waste air as shown in the below drawing

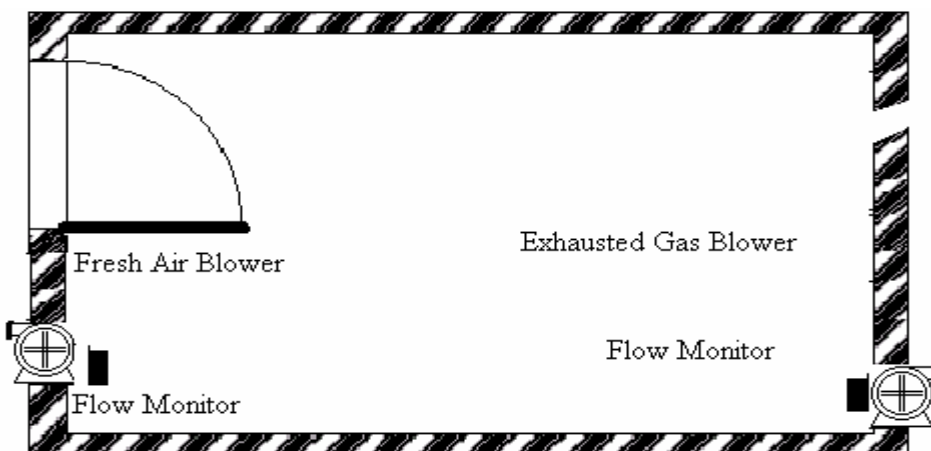

- The room is provided with exhausted gas blower and fresh air blower
- The flow sensor control the blowing in and out operation
- Over pressure is permitted at no time.

- The fresh blower will run only if the flow monitor senses that the exhausted gas blower works properly.
- If any irregularity takes place on air in blower and air out blower, the warning lamp will light.

The control circuit for the traditional ventilation system is shown below:

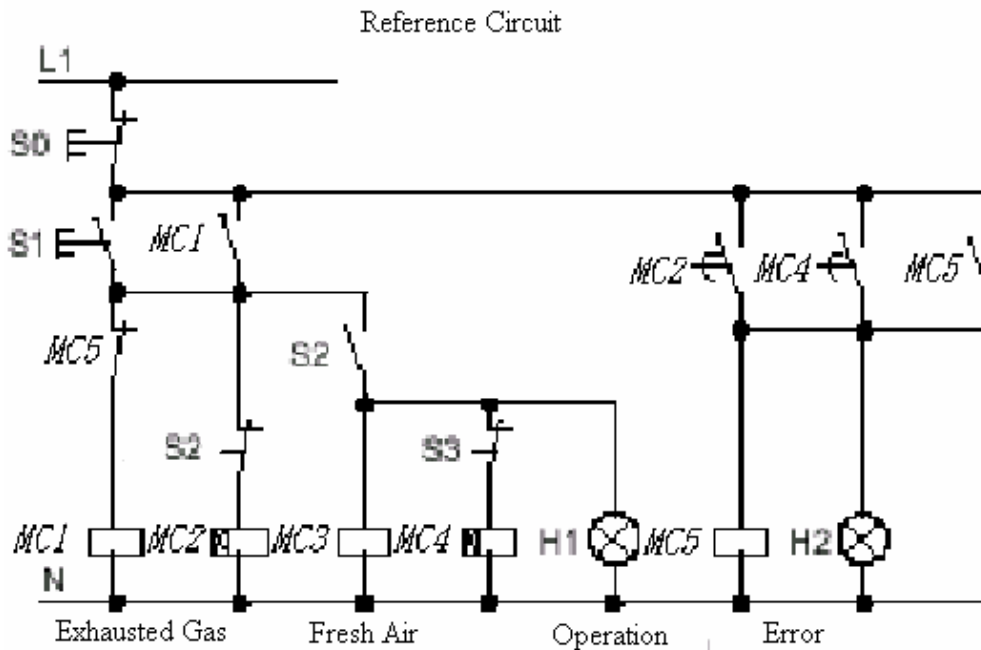

The ventilation system is wholly controlled by the airflow monitor. If there is no flow air in the room after a designated duration of time, the system will activate the warning system so the user shall shut off the system.

Devices Applied

MC1 main contactor

MC2 main contactor

S0(NC contact) stop switch

S1(NO contact) start switch

S2(NO contact) air flow monitor

S3(NO contact) air flow monitor

H1operation indicator

H2 alarm light

Wiring Diagram and Program with SG2 applied in Ventilation System.

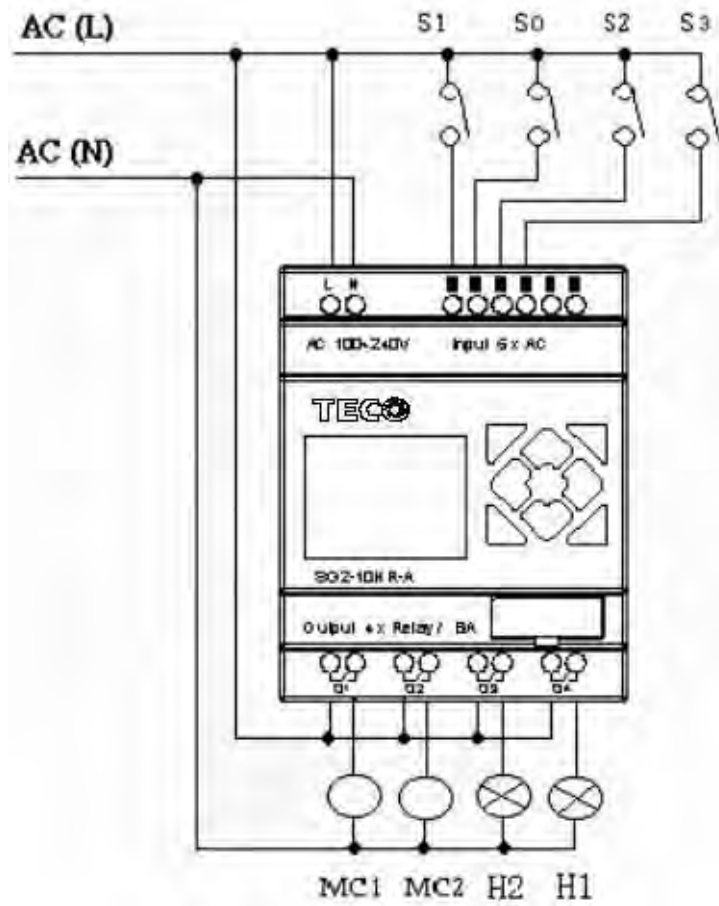

Ladder & FUNCTION :

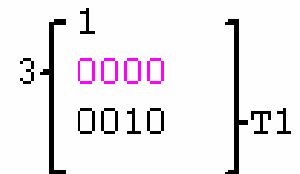
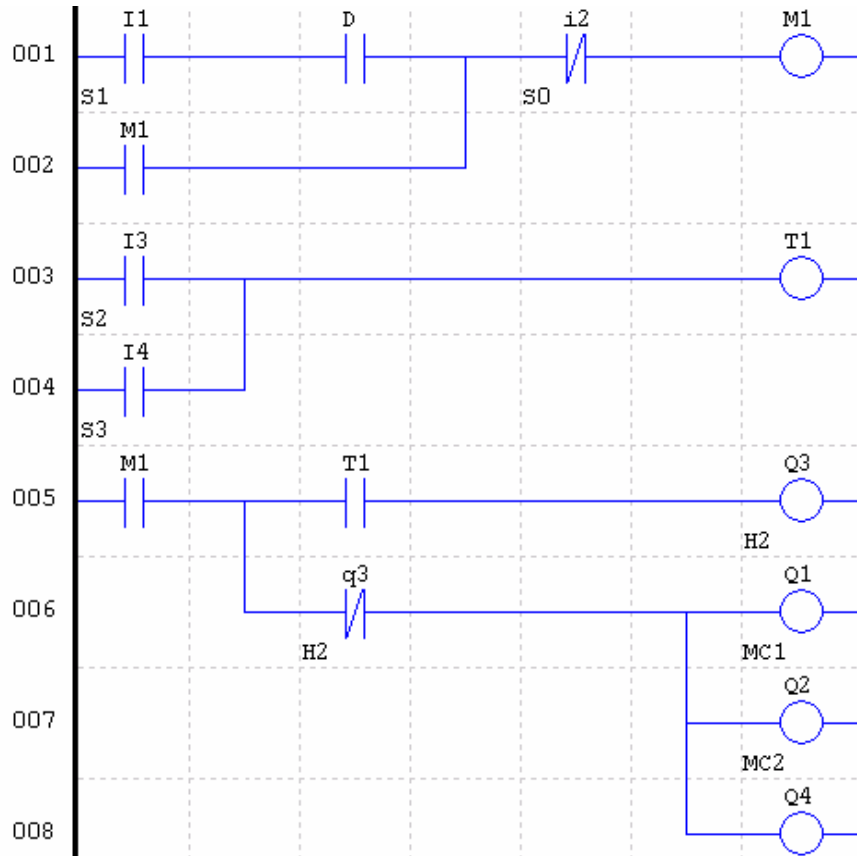

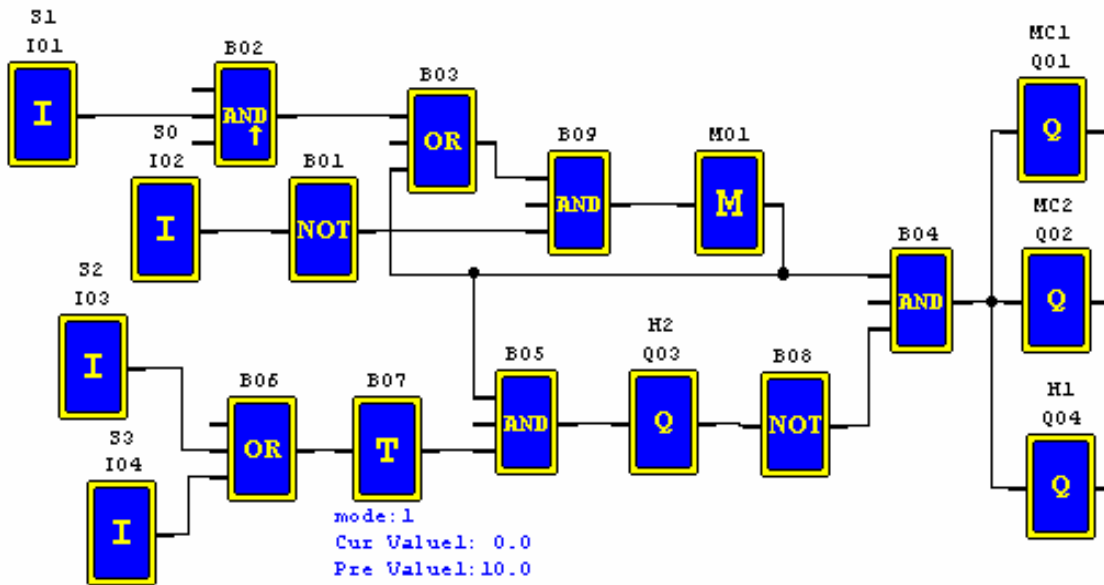
FBD Operation Flow :**4. Plant Gate Control****4.1 Requirements for Plant Gate Control**

The main purpose of the plant gate is to control the access of truck, which is manually operated by the gate guard.

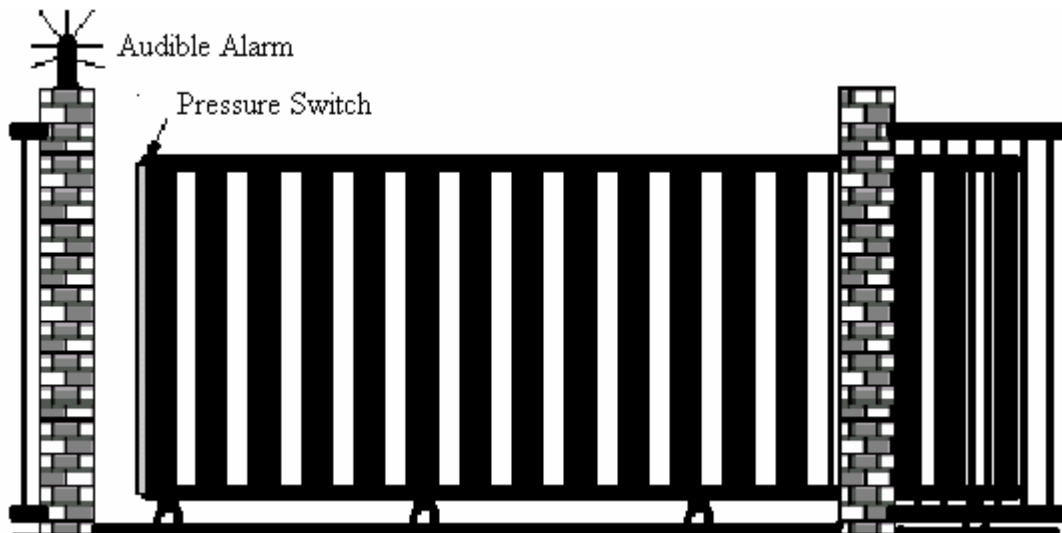

- The door guard controls and oversees the opening, closing of the plant door gate.
- The stop switch can be activated at any time regardless of the gate in fully open or close condition.
- The alarm light will be activated for 5 seconds in advance before the gate operation.
- The damper is provided on the gate. Gate closing operation, whenever the damper is contacted by the gate, stops.

4.2 Traditional Control Circuit for Gate System

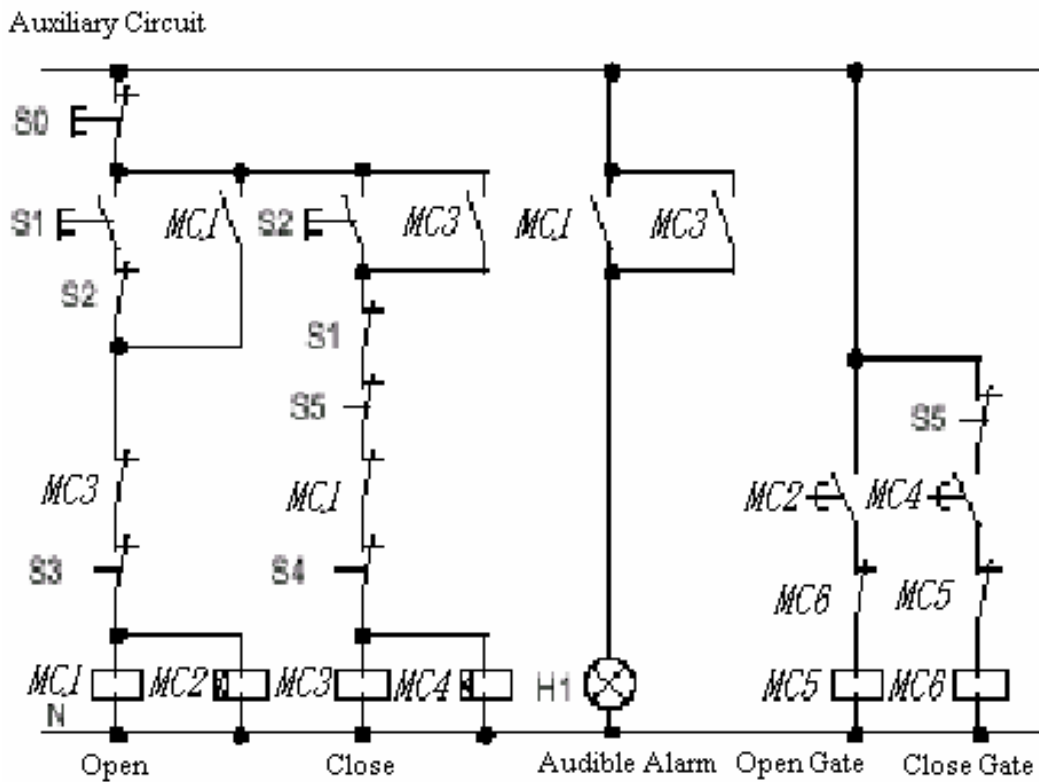

Devices Applied

- MC1 Main Electromagnetic Contactor
- MC2 Main Electromagnetic Contactor
- S0(NC contact) stop switch
- S1(NO contact) open switch
- S2(NO contact) close switch
- S3(NC contact) open safe damper
- S4(NC contact) close safe damper

Wiring Diagram and Program with SG2 applied in Plant Gate

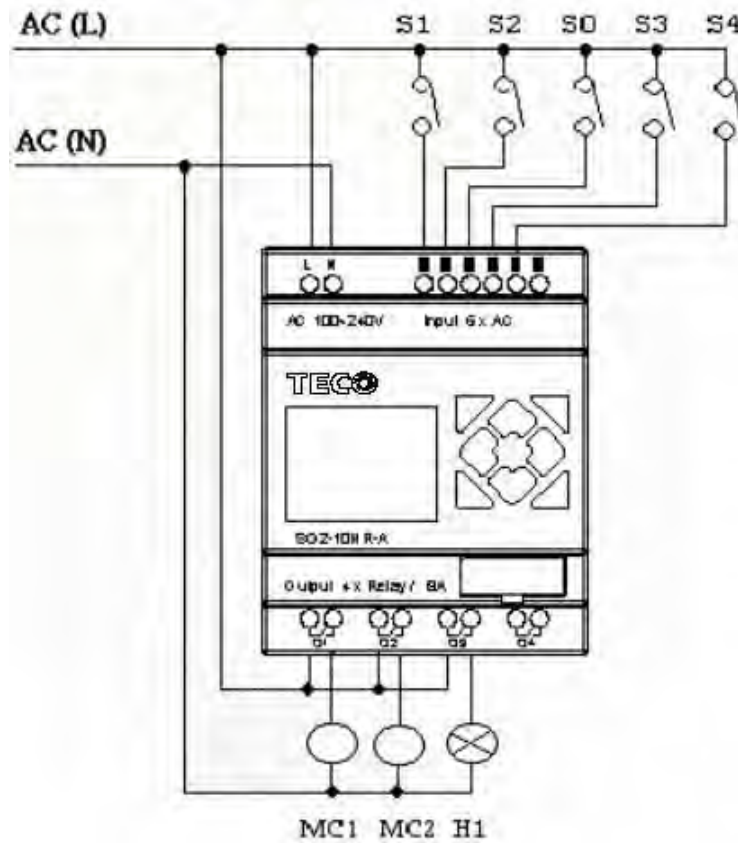

Ladder & FUNCTION :

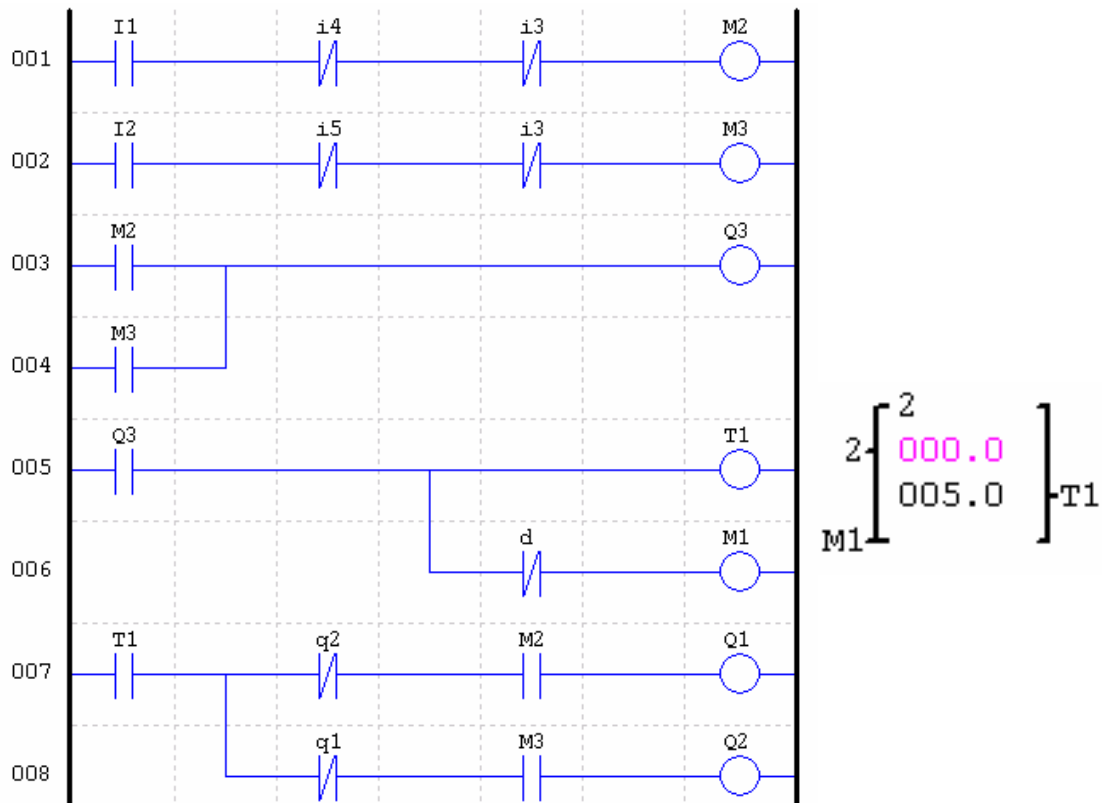

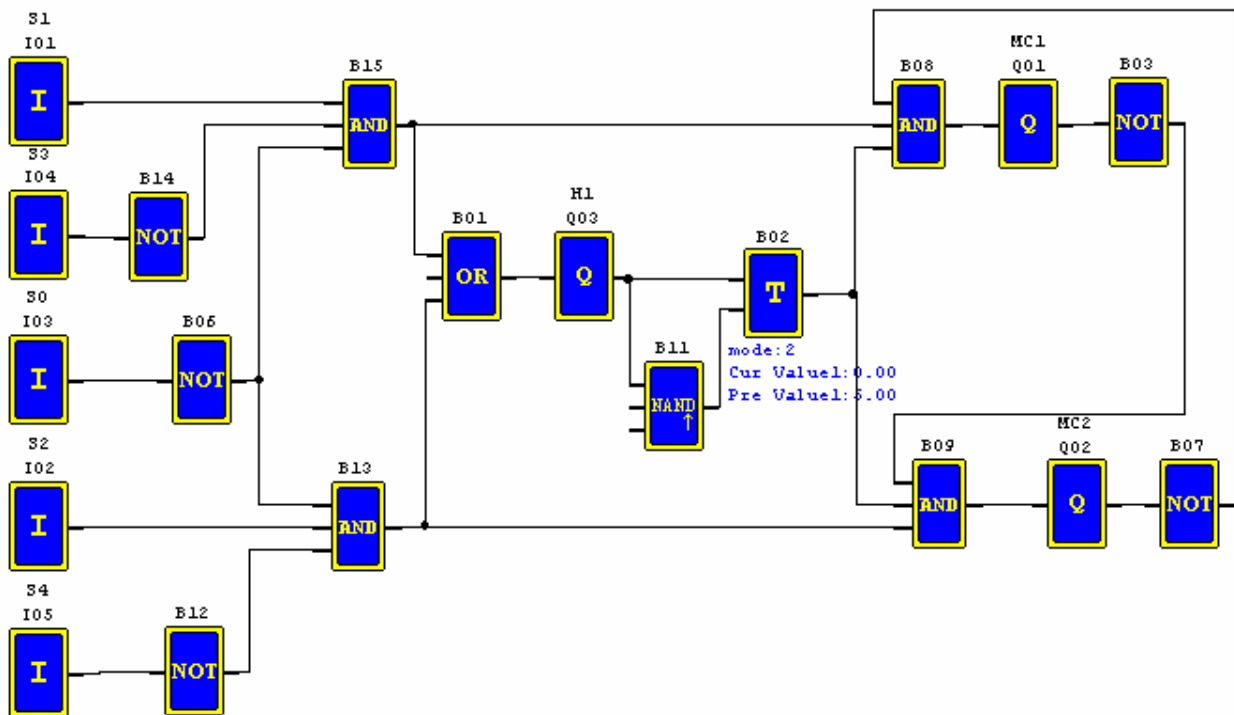
FBD:

5 . Counting Control for Packing Machine

Requirement :

- 1) The packing cycle is that it begins counting the finished products in the assemble line, when the counting value reaches 12, it proceeds packing operation which takes 5 seconds. After finished, it begins a new cycle.
- 2) It simultaneous counts the finished packs of product.
- 3) In case of power failure, the counting remains unchanged.

Analysis :

- 1) A transducer is employed to produce the pulse signal when the transducer detects the arrival of a product. A counter generates an output when the counting value reaches 12 and a timer is employed to have a delay of five seconds.
- 2) The counter will be operated in mode 3 or mode 4 in an effort to keep the accurate counting even in case of power failure.

Devices Applied

I1 : counting sensor;

S1 : reset the counting value to zero;

MC1 : packing

Wiring Diagram and Program with SG2 applied at for Packing Machine

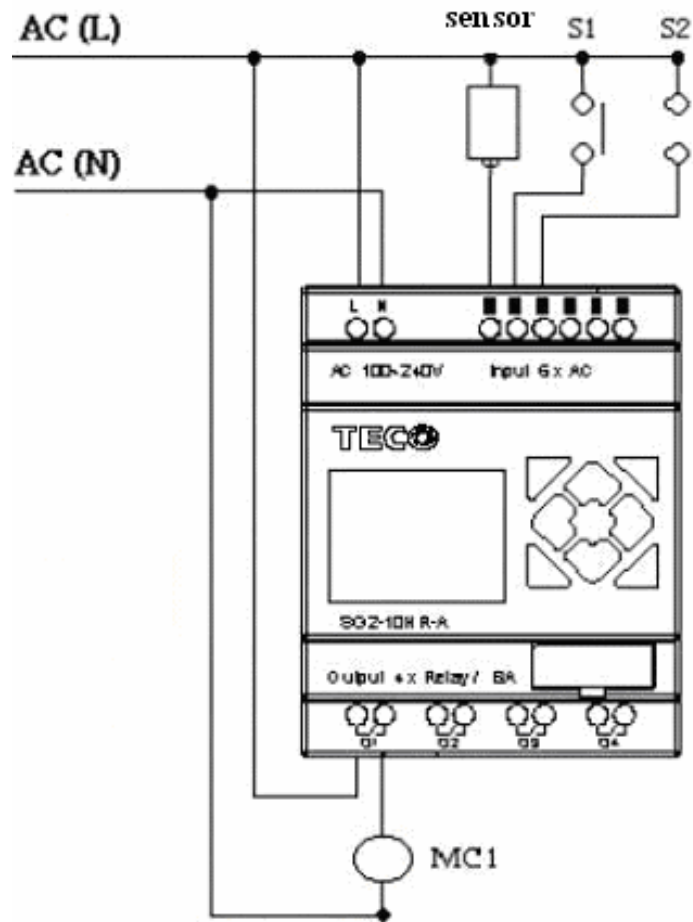

Ladder & FUNCTION :

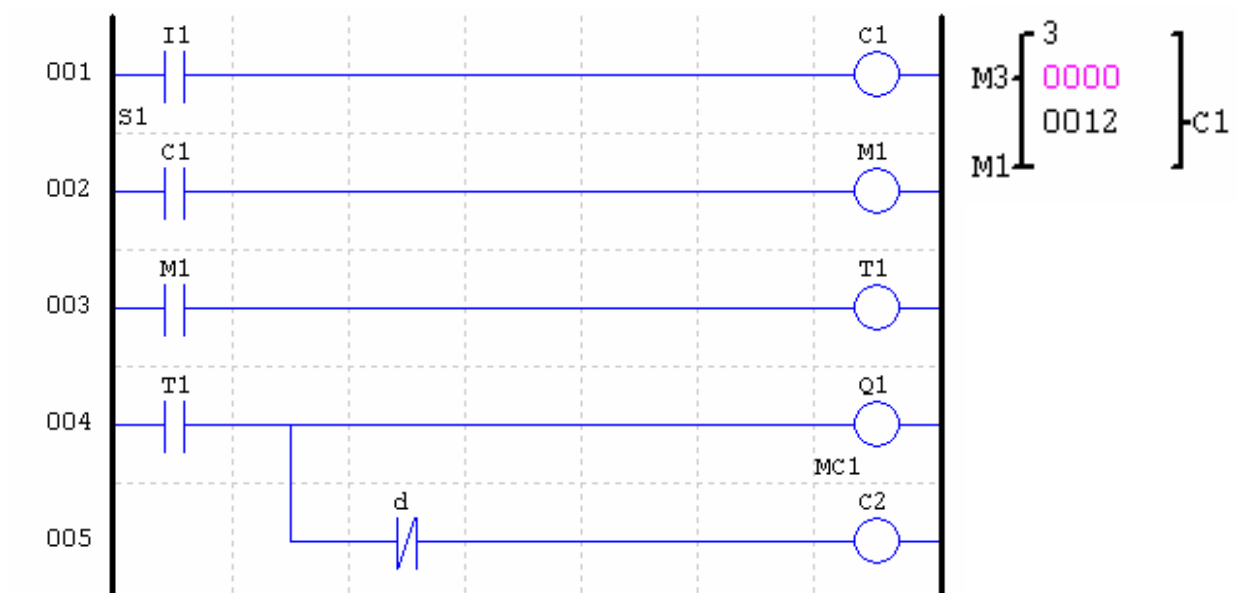

FBD :

